

Recording/Playback with the Connected Equipment

Dubbing onto another tape recorder

Set this unit to the playback mode and another tape recorder to the recording mode.

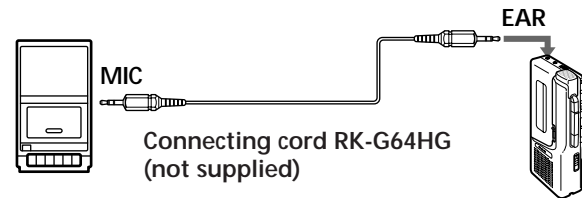

Recording from another tape recorder

Set this unit to the recording mode and another tape recorder to the playback mode. In this case set VOR to OFF.

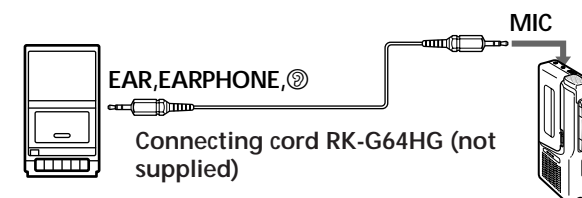

Recording with an External Microphone

Connect a microphone to MIC. When using a plug-in-power system microphone, the power to the microphone is supplied from this unit.

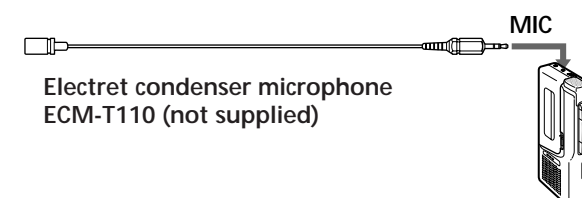

Note

When recording with an external microphone, the VOR system may not work properly because of the difference in sensitivity.

Precautions

On power

- Operate the unit only on 3 V DC. For AC operation, use the AC adaptor recommended for the unit. Do not use any other type. For battery operation, use two size AA (R6) batteries.

On the unit

- Use only the **MICROCASSETTE™** (standard microcassettes) with this unit. Non-standard cassettes cannot be used because their "L" dimension (see illustration) is different.

Standard

Only standard microcassettes have a small indentation of side A.

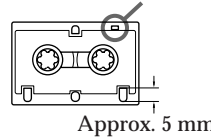

Non-standard

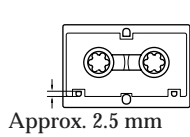

- Do not leave the unit in a location near heat sources, or in a place subject to direct sunlight, excessive dust or mechanical shock.
- Should any solid object or liquid fall into the unit, remove the batteries or disconnect the AC power adaptor, and have the unit checked by qualified personnel before operating it any further.
- Keep personal credit cards using magnetic coding or spring-wound watches etc. away from the unit to prevent possible damage from the magnet used for the speaker.
- When you do not use the unit for long, remove the batteries to avoid damage caused by battery leakage and subsequent corrosion.
- If the unit has not been used for long, set it in the playback mode and warm it up for a few minutes before inserting a cassette.

RECYCLING NICKEL-CADMIUM BATTERIES (supplied with M-679V only)



NICKEL-CADMIUM BATTERY. BATTERY MUST BE RECYCLED OR DISPOSED OF PROPERLY.

Nickel-Cadmium batteries are recyclable. You can help preserve our environment by returning your unwanted batteries to your nearest Sony Service Center or Factory Service Center for collection, recycling or proper disposal.

Note: In some areas the disposal of nickel-cadmium batteries in household or business trash may be prohibited.

For the Sony Service Center nearest you call 1-800-222-SONY (United States only)

For the Factory Service Center nearest you call 416-499-SONY (Canada only)

Caution: Do not handle damaged or leaking nickel-cadmium batteries.

If you have any questions or problems concerning your unit, please consult your nearest Sony dealer.

Troubleshooting

Should any problem persist after you have made these checks, consult your nearest Sony dealer.

A cassette cannot be inserted.

- The cassette is being inserted in the wrong way. (The cassette should be inserted in the lid with the tape side facing you.)
- ▶ has been already pressed.

● cannot be pressed.

- There is no cassette in the cassette compartment.
- The cassette tab has been removed.

● or ◀ cannot be pressed.

- The tape has reached the end.
- After the automatic shut-off, ◀ PAUSE is slid in the direction of the arrow.

The unit does not operate.

- The batteries have been inserted with incorrect polarity.
- The batteries are weak. Replace both batteries with new ones.

- ◀ PAUSE is slid in the direction of the arrow.

- The AC power adaptor or car battery cord is connected to the unit only and you are going to use the unit on batteries.

No sound comes from the speaker.

- The earphone is plugged in.
- The volume is turned down completely.

The sound drops out or comes with excessive noise.

- The volume is turned down completely.
- The batteries are weak. Replace both batteries with new ones.
- The head is contaminated. See "Maintenance".

Tape speed is too fast or too slow in the playback mode.

- Improper setting of the TAPE SPEED switch. Set it to the same speed as that used for recording.

Tape speed is faster than the normal playback speed.

- The FAST PB switch is slid in the direction of the arrow.
- The TAPE SPEED switch is set between the 1.2 cm and 2.4 cm positions.

Recording cannot be made.

- Connection is made incorrectly.
- The batteries are weak. Replace both batteries with new ones.
- The head is contaminated.
- Improper setting of the VOR switch. Set it to H or OFF.

Recording is interrupted.

- The VOR switch is set to H or L. When you do not use VOR, set it to OFF.

Recording cannot be erased completely.

- The head is contaminated.

Maintenance

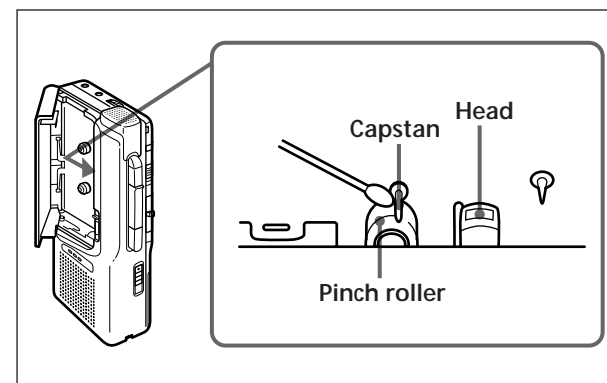

To clean the tape head and path

Press ◀ and wipe the head, capstan and the pinch roller with a cotton swab, moistened with alcohol every 10 hours of use.

To clean the exterior

Use a soft cloth slightly moistened in water. Do not use alcohol, benzine or thinner.

Specifications

Tape

MICROCASSETTE™ (normal position type)

Recording system

2-track 1-channel monaural

Speaker

Approx. 3.6 cm (1⁷/₁₆ in.) dia.

Tape speed

2.4 cm/s (1⁵/₁₆ ips), 1.2 cm/s (1⁵/₃₂ ips)

Frequency range

250 - 4,000 Hz

Input

Microphone input jack (minijack/PLUG IN POWER)
sensitivity 0.24 mV for 3 kilohms or lower impedance microphone

Output

Earphone jack (minijack) for 8 - 300 ohms earphone

Power output (at 10% harmonic distortion)

M-629V/679V	160 mW
M-729V	260 mW

Battery life (recording)

See "Preparing Power Sources".

Power requirements

3 V DC
Two size AA (R6) batteries

Dimensions (w/h/d)

Approx. 65.1 × 121.4 × 25.2 mm (2⁵/₈ × 4⁷/₈ × 1 in.) incl. projecting parts and controls

Mass

Approx. 130 g (4.6 oz) incl. batteries

Supplied accessories

Micro cassette tape (1) (M-629V/729V European model only)
Size AA (R6) batteries (2) (M-629V/729V European model only)
AC power adaptor (1) (M-679V only)
Battery charge adaptor (1) (M-679V only)
Rechargeable batteries NC-AA, 1.2 V, 600 mAh, Ni-Cd (2) (M-679V only)

Design and specifications are subject to change without notice.

Optional accessories

Microcassette MC-60, MC-30
Earphone ME-81, ME-L82
Connecting cord RK-G64HG (miniplug to miniplug with attenuator)
Electret condenser microphone ECM-T110
AC power adaptor AC-E30HG
Car battery cord DCC-E130L

This warranty is valid only in the United States.

SONY

Microcassette™ - Corder

Operating Instructions

M-629V/679V/ 729V

Sony Corporation © 1996 Printed in China

For customers in the United States

Owner's Record

The model number is located at the bottom and the serial number is located inside the battery compartment. Record these numbers in the spaces provided below. Refer to these numbers whenever you call upon your Sony dealer regarding this product.

Model No. _____ Serial No. _____



You are cautioned that any changes or modifications not expressly approved in this manual could void your authority to operate this equipment.

WARNING

To prevent fire or shock hazard, do not expose the unit to rain or moisture.

Welcome!

Thank you for purchasing the Sony Microcassette-Corder. Some features are:

- The BATT lamps indicate remaining battery power in two steps and the  lamp indicates when to replace the batteries.
- The CUE MARKER (M-729V only) function locates a specific position of a dictation.
- The FAST PB (fast playback) function enables you to review the contents approx. 20% faster than normal playback.
- The VOR (Voice Operated Recording) system starts and stops recording automatically in response to the sound.
- Edit function—You can start recording directly from the playback mode by pressing the  button to correct a previously recorded portion.
- Tape counter
- Automatic shut-off mechanism at the end of the tape (in the recording/playback mode only)
- Stop-pause-release function—The pause switch is released automatically when the  button is depressed, so that you don't miss a recording chance.

About This Manual

The instructions in this manual are for the M-629V, M-679V and M-729V. Before you start reading, check your model number. The M-729V is the model used for illustration purposes. Any differences in operation are clearly indicated in the text, for example, "M-729V only".

Preparing Power Sources

Choose one of the following power sources.

Dry Batteries

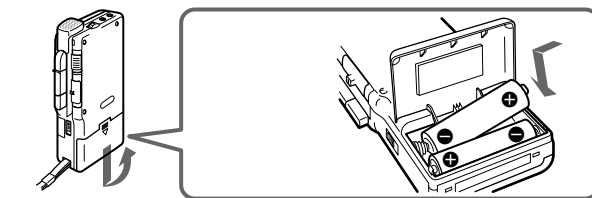

Make sure that nothing is connected to the DC IN 3V jack.

- 1 Open the battery compartment lid.
- 2 Insert two size AA (R6) batteries with correct polarity and close the lid.

If the battery compartment lid is accidentally detached

Attach it as illustrated.

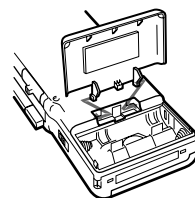

When to replace the batteries

Replace the batteries with new ones when the BATT lamps go off and the  lamp flashes.

The BATT lamps change as illustrated:

When batteries are new

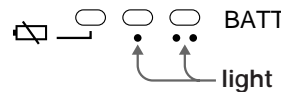

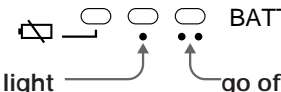

When batteries become weak

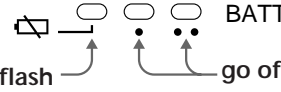

Replace batteries



Notes

- The unit will play back normally for a while, even after the  lamp flashes. However, replace the batteries as soon as you can. If you do not, the playback cannot be made with normal sound, noise may be recorded and the recorded sound will not be loud enough.
- In the following cases you do not need to replace the batteries:
 - if the BATT lamps flash with the playback sound when you turn up the volume.
 - if the  lamp lights momentarily when the tape starts running or at the end of the tape.
 - if the  lamp flashes during FF (CUE) or REW (REVIEW).
- In some cases when the unit is used with rechargeable batteries (supplied with M-679V only or not supplied), only one BATT lamp will light even though the batteries have been fully charged.

Battery life (Approx. hours)

Batteries	Recording
Sony R6P (SR)	5.5
Sony alkaline LR6 (SG)	19.0
NC-AA (M-679V only)	5.5

House current

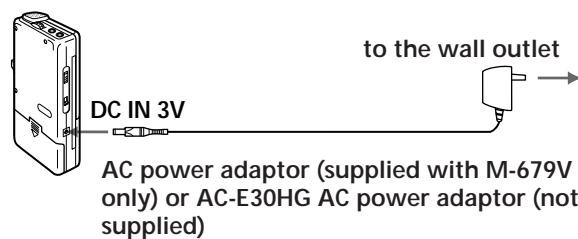

Connect the AC power adaptor to DC IN 3V and to a wall outlet. Use the AC power adaptor (supplied with M-679V only) or the AC-E30HG AC power adaptor (not supplied). Do not use any other AC power adaptor.

Polarity of the plug



Rechargeable batteries (supplied with M-679V only)

Charge the rechargeable batteries only with the supplied charge adaptor and the AC power adaptor. The rechargeable batteries can be charged approximately 500 times.

Be sure to charge the rechargeable batteries for approximately 8 hours before using them. The unit can be used for recording for approximately 5.5 hours with the fully charged rechargeable batteries.

To charge

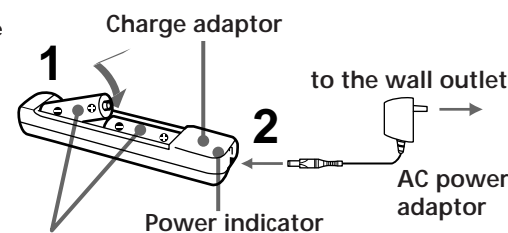

Rechargeable batteries NC-AA

The power indicator of the charge adaptor remains lit as long as power is supplied from the wall outlet.

To use

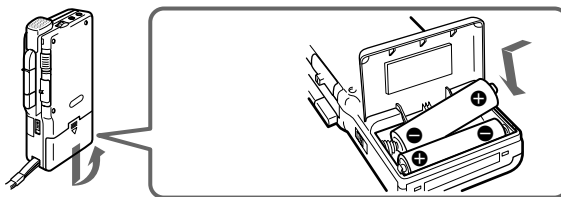



Notes





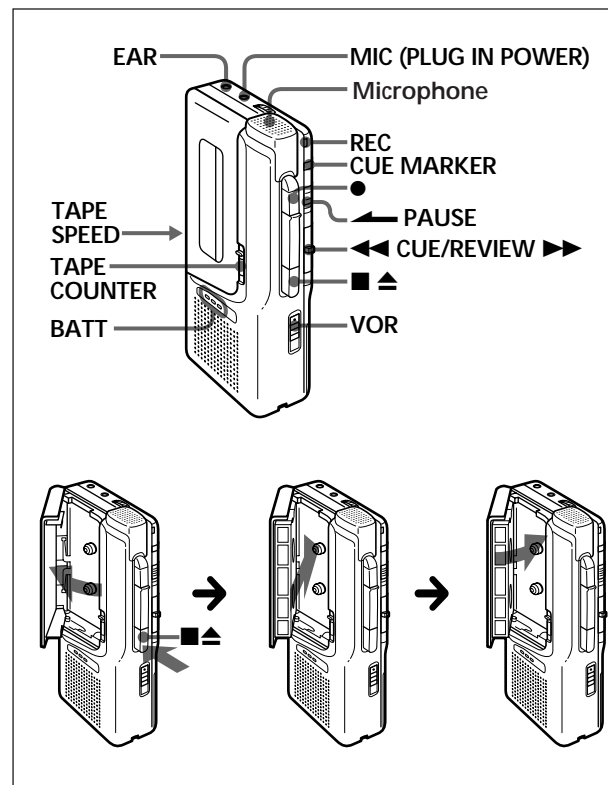

- Use the supplied two rechargeable batteries only with the supplied charge adaptor.
- If there is distortion of sound or excessive noise, or if the unit does not operate properly, turn off the unit and recharge the two rechargeable batteries together.
- The rechargeable batteries will discharge even when not in use. Be sure to charge them before use.
- Recharge the two rechargeable batteries together. Otherwise, the charging cannot be done.
- Be sure to remove the rechargeable batteries from the charge adaptor to avoid overcharging (more than 20 hours) when charging has been completed.
- Charging and operation should be made in temperature ranges 5°C to 40°C (40°F to 104°F).
- The charge adaptor will become warm during charging but this is not a sign of problem.
- Do not use or leave the charge adaptor in a location near heat sources or in a place subject to direct sunlight or excessive moisture.
- Unplug the AC power adaptor from the wall outlet when it is not to be used for long.
- Do not attempt to charge dry batteries.

Recording

Make sure that nothing is connected to MIC.



- 1 Press the reset button of the TAPE COUNTER.
- 2 Press  and insert a standard microcassette with the side to start recording facing the lid.
- 3 Select the desired tape speed.
2.4 cm for optimum sound (recommended for normal use):
A 30-minute recording can be made using both sides of the MC-30 microcassette.
1.2 cm for longer recording time: A 60-minute recording can be made using both sides of the MC-30 microcassette.
- 4 Set VOR to H, L or OFF.
If you set VOR to H or L, the unit automatically starts recording the sound and pauses when there is no sound (you can save tapes and batteries).
H: To record at meeting or in a quiet and/or spacious place.
L: To record for dictation or in a noisy place.
When the sound is not loud enough, set it to OFF, or the unit may not start recording.
- 5 Press .
Recording starts. While the tape runs, the REC lamp lights and flashes depending on the strength of the sound.
Recording level is fixed.

To	Press or slide
Stop recording	
Start recording during playback	 during playback (the unit becomes in the recording mode)
Review the portion just recorded	Push up  CUE/  REVIEW toward  REVIEW during the recording. Release the button at the point to start playback.
Pause recording	Slide  PAUSE in the direction of the arrow. The REC and BATT lamps go off.
Take out a cassette	

Note

Select the 2.4 cm tape speed for recording, if you play back the recorded tape with another unit. Otherwise, the sound quality may be changed.

Notes on VOR (Voice Operated Recording)

- The VOR system depends on the environmental conditions. If you cannot get the desired results, set VOR to OFF.
- When you use the system in a noisy place, the unit will stay in the recording mode. If the sound is too soft, on the contrary, the unit will not start recording. Set VOR to H (high) or L (low) depending on the conditions.

To monitor the sound

Connect the earphone (not supplied) to EAR jack. The monitor volume cannot be adjusted by VOL.

To prevent a cassette from being accidentally recorded over

Break out and remove the cassette tabs. To reuse the cassette for recording, cover the tab hole with adhesive tape.

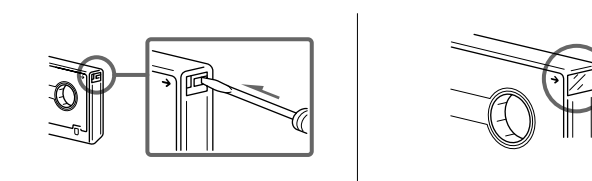

Recording cue markers (M-729V only)

While recording, you can record a special signal on the tape to mark a specific position. At the desired position, press CUE MARKER to record a signal. The REC lamp goes off and a signal will be recorded on the tape. If you want to record a signal longer than that, press CUE MARKER as long as you want. During cue and review, you will hear the beep sound at the signal position. During playback, you will hear the signal with low frequency sound at the signal position.









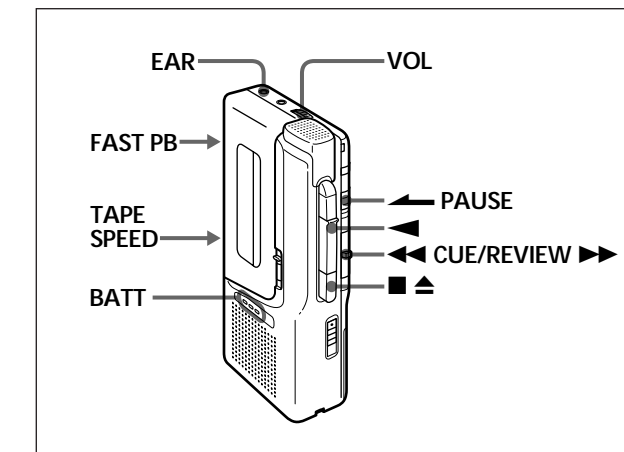



Notes

- We recommend recording cue markers when there is a break in the sound.
- During cue and review, the beep sounds differently.
- The beep may sound differently depending on the marked position on the tape because the winding speed varies from the beginning to the end of the tape.

Playing a Tape



- 1 Insert a cassette with the side to start playing facing the lid.
- 2 Select the tape speed to the same speed as that used for recording.
- 3 Press .
- 4 Adjust the volume.



To	Press or slide
Stop playback/stop fast forward or rewind*	
Pause playback	Slide  PAUSE in the direction of the arrow. The BATT lamp goes off.
Fast forward	Slide  CUE/  REVIEW toward  CUE during stop.**
Rewind	Slide  CUE/  REVIEW toward  REVIEW during stop.**
Search forward during playback (CUE)	Keep  CUE/  REVIEW pushed down during playback and release it at the point you want.**
Search backward during playback (REVIEW)	Keep  CUE/  REVIEW pushed up during playback and release it at the point you want.**

- * If you leave the unit after the tape has been wound or rewound, the batteries will be consumed rapidly. Be sure to depress .
- ** The tape moves faster in the rewind/REVIEW mode than in the fast forward/CUE mode.



Note

If the tape is completely rewound while searching backward during playback (REVIEW), the  CUE/  REVIEW switch may not return to the center position when you release the switch. In this case, push back the switch to the center to start playback.

To increase the playback speed

Slide the FAST PB switch in the direction of the arrow. The playback speed will be increased. To return to the original speed, slide the FAST PB switch to the original position.

At the end of the tape

In the recording or playback mode, the tape stops at the end of the tape and the locked buttons will be released automatically (Automatic shut-off mechanism). After fast forward or rewind, be sure to set  CUE/  REVIEW back to the center.