

# *Personal Audio System*

---

Operating Instructions

*ZS-D5*

## Warning

To prevent fire or shock hazard, do not expose the player to rain or moisture.

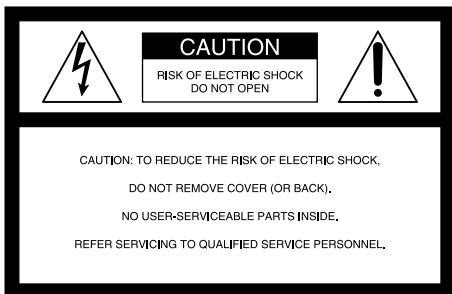

This symbol is intended to alert the user to the presence of uninsulated "dangerous voltage" within the product's enclosure that may be of sufficient magnitude to constitute a risk of electric shock to persons.



This symbol is intended to alert the user to the presence of important operating and maintenance (servicing) instructions in the literature accompanying the appliance.

### CAUTION

The use of optical instruments with this product will increase eye hazard.

## Warning

Do not install the appliance in a confined space, such as a bookcase or built-in cabinet.

### For customers in Canada

To prevent electric shock, match wide blade of plug to wide slot, fully insert.

## Information

### For customers in the United States

This equipment has been tested and found to comply with the limits for a Class B digital device, pursuant to Part 15 of the FCC Rules. These limits are designed to provide reasonable protection against harmful interference in a residential installation. This equipment generates, uses and can radiate radio frequency energy and, if not installed and used in accordance with the instructions, may cause harmful interference to radio communications. However, there is no guarantee that interference will not occur in a particular installation. If this equipment does cause harmful interference to radio or television reception, which can be determined by turning the equipment off and on, the user is encouraged to try to correct the interference by one or more of the following measures:

- Reorient or relocate the receiving antenna.
- Increase the separation between the equipment and receiver.
- Connect the equipment into an outlet on a circuit different from that to which the receiver is connected.
- Consult the dealer or an experienced radio/TV technician for help.

You are cautioned that any changes or modifications not expressly approved in this manual could void your authority to operate this equipment.

### Owner's Record

The model number is located at the bottom and the serial number is located in the battery compartment.

Record the model number and serial number in the space provided below. Refer to these numbers whenever you call your Sony dealer regarding this product.

Model No. ZS-D5

Serial No. \_\_\_\_\_

---

# Table of contents

---

## Basic Operations

- 4 Playing a CD
  - 6 Listening to the radio
  - 8 Playing a tape
  - 10 Recording on a tape
- 

### CD Player

- 12 Using the display
- 13 Locating a specific track
- 14 Playing tracks repeatedly (Repeat Play)
- 15 Playing a single track (Single Track Play)
- 16 Playing tracks in random order (Shuffle Play)
- 17 Creating your own program (Program Play)

### The Radio

- 19 Presetting radio stations
- 20 Playing preset radio stations

### The Tape Player

- 21 Finding the beginning of a track
- 22 Recording the tracks on CD by specifying the tape length

### The Timer

- 28 Setting the clock
- 29 Waking up to music
- 31 Falling asleep to music
- 32 Timer-recording radio programs

### Setting Up

- 34 Choosing the power sources
- 36 Connecting optional components
- 39 Selecting the audio emphasis (Sound Mode/MEGA BASS)

### Additional Information

- 40 Precautions
- 42 Troubleshooting
- 45 Maintenance
- 46 Specifications
- 47 Index

# Playing a CD

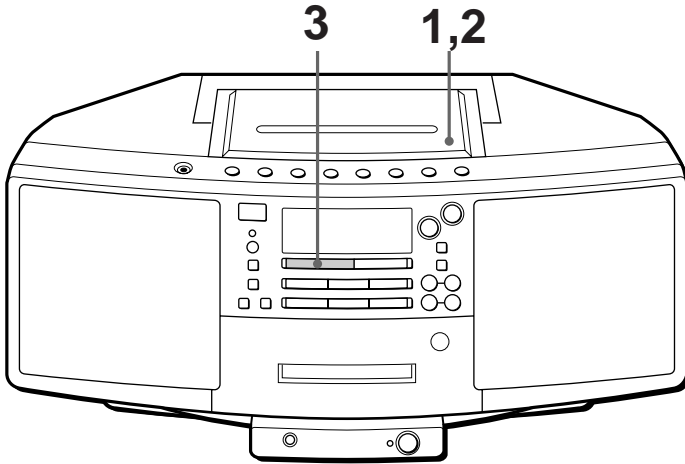

Connect the supplied AC power cord (see page 34.)

**1**

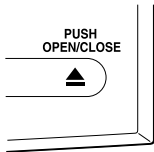

Press **6** PUSH OPEN/CLOSE and place the CD on the CD compartment.

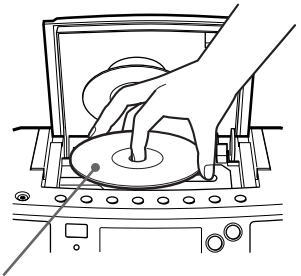

With the label side up

**2**

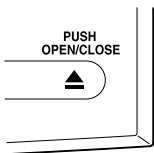

Close the CD compartment.

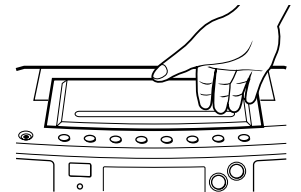

**3**



Press **^** .  
(On the remote, press **( )** on the CD section.)

The player turns on (direct power-on) and the player plays all the tracks once.

Display



Track number    Playing time

## Use these buttons for additional operations

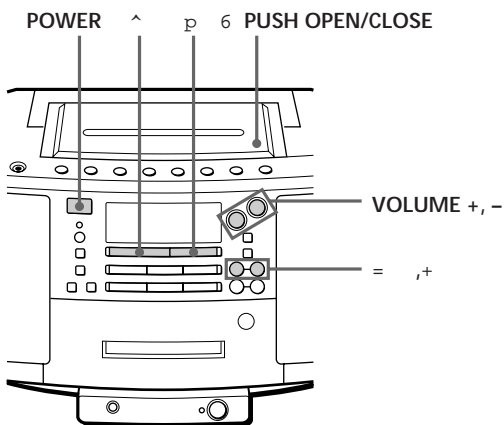
**Tip**

Next time you want to listen to a CD, just press **^**. The player turns on automatically and starts playing the CD.

To	Press
Adjust the volume	VOLUME +, -
Stop playback	P
Pause playback	^ (On the remote, press P ). Press again to resume play after pause.
Go to the next track	+
Go back to the previous track	=
Remove the CD	6 PUSH OPEN/CLOSE
Turn on/off the player	POWER

# Listening to the radio

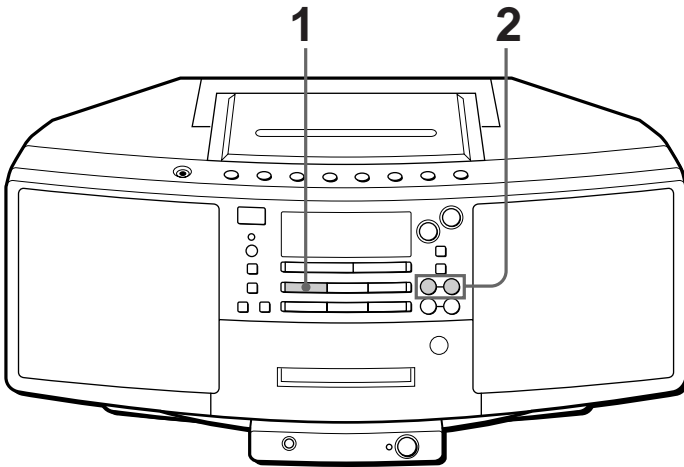

Connect the supplied AC power cord (see page 34.)

1

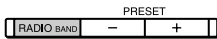

Press **BAND** until the band you want appears in the display (direct power-on).

Display

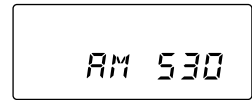

2



Hold down **TUNE/TIME SET +** or **-** until the frequency digits begin to change in the display.

The player automatically scans the radio frequencies and stops when it finds a clear station.

If you can't tune in a station, press **TUNE/TIME SET +** or **-** until you tune in the station you want.

Indicates an FM stereo broadcast.

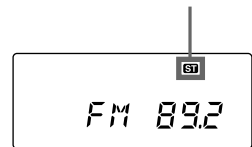

Use these buttons for additional operations

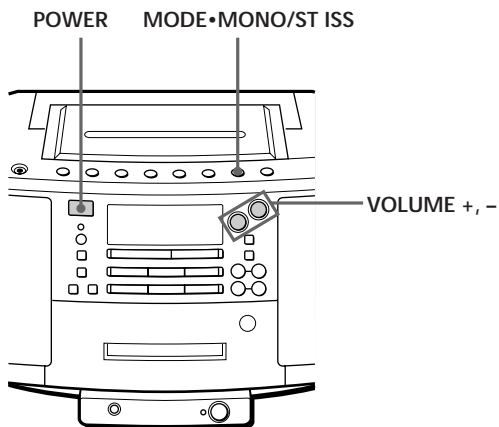

To	Press
Adjust the volume	VOLUME +, -
Turn on/off the radio	POWER

#### Tips

- If the FM broadcast is noisy, press **MODE•MONO/ST ISS** until "Mono" appears in the display and the radio will play in monaural.
- Next time you want to listen to the radio, just press the **BAND** button. The player turns on automatically and starts playing the previous station.

#### To improve broadcast reception

Reorient the antenna for FM. Reorient the player itself for AM.

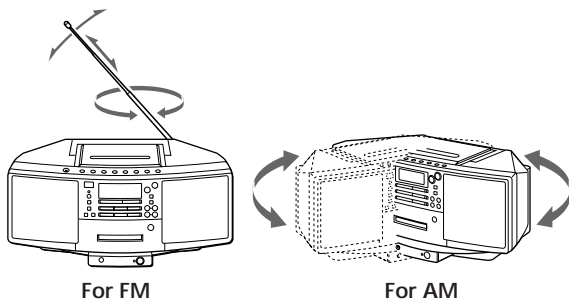

# Playing a tape

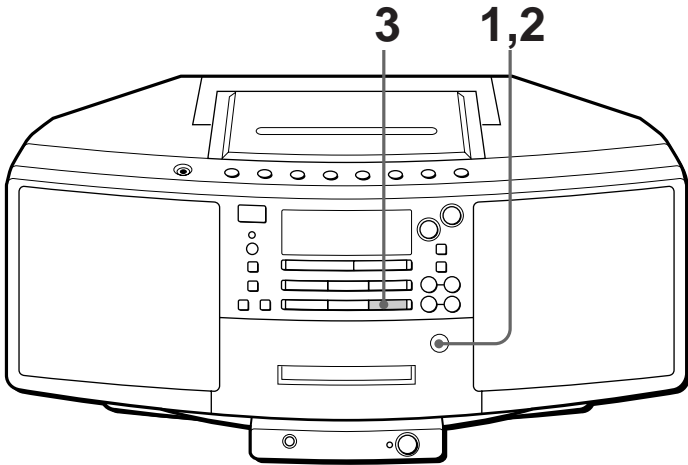

Connect the supplied AC power cord (see page 34.)

1



Press  $\Delta$  PUSH OPEN/CLOSE to open the tape compartment and insert a recorded tape. Use TYPE I (normal), TYPE II (high position) and TYPE IV (metal) tapes.

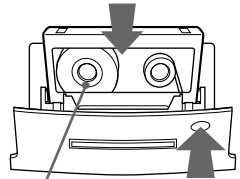

With the side you want to play facing forward

2



Press  $\Delta$  PUSH OPEN/CLOSE to close the compartment.

3



Press ( . )  
(On the remote, press TAPE ( . )

The player turns on (direct power-on) and starts playing.

Display



Tape counter



## Use these buttons for additional operations

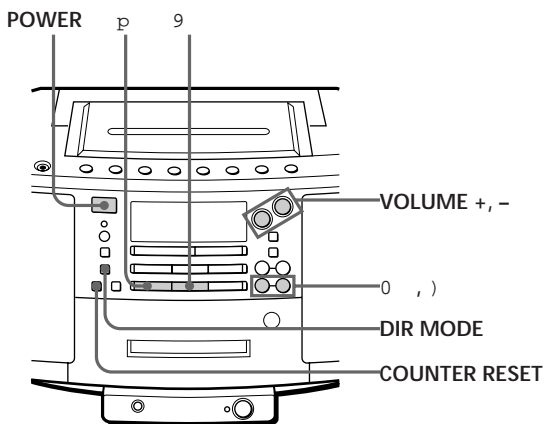

## Tips

- Press COUNTER RESET to reset the counter to "000."
- Next time you want to listen to a tape, just press ( or 9 . The player turns on automatically and starts playing the tape.

To	Press
Adjust the volume	VOLUME +, -
Stop playback	p
Play the reverse side	9
Fast-forward or rewind the tape	) or 0
Eject the cassette	6 PUSH OPEN/CLOSE
Turn on/off the player	POWER

## To select the direction of the tape

Press DIR MODE repeatedly.

To play	Display shows
One side of the tape	→
Both sides of the tape from the front side to reverse side only	↔
Both sides of the tape repeatedly	↻

# Recording on a tape

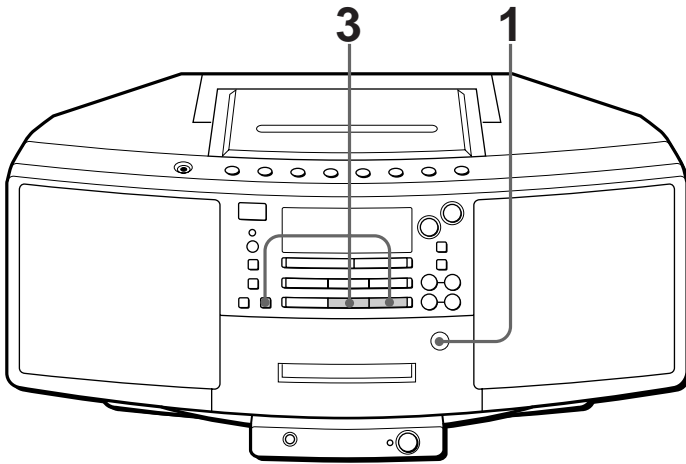

Connect the supplied AC power cord (see page 34.) To record on a MiniDisc or DAT recorder, connect the component (see page 36.)

1



Press 6 PUSH OPEN/CLOSE to open the tape compartment, and insert a blank tape. Use TYPE I (normal) tape only. Press 6 PUSH OPEN/CLOSE again to close the compartment.

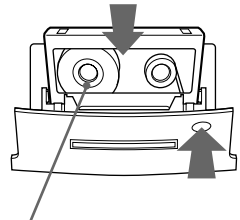

With the side you want to record on facing forward

2

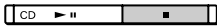

Select the program source you want to record.

To record from the CD player, insert a CD (see page 4) and press **p** on the CD section.

Display

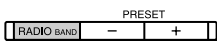
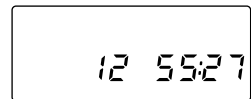

To record from the radio, press **BAND** and tune in the station you want (see page 6.)

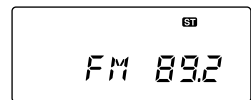

## 3



Start recording.

Press  $r/P$  and then ( .  
To record on the reverse side, press 9 . (On the remote, while keeping  $r/P$  pressed, press TAPE ( or 9 .)

To record from the CD player, press ^ to start playing the CD tracks. (On the remote, press ( on the CD section.)

#### Note

On the player, press ( within 4 seconds after  $r/P$  is pressed.

Recording from the CD player



Recording from the radio

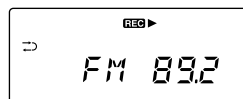

#### Tips

- Adjusting the volume or the audio emphasis (see page 39) will not affect the recording level.
- When ⇄ or ⇄ is displayed, recording will be made on both sides of the tape. To record on one side, press DIR MODE to display ⇄.
- If the AM radio makes a whistling sound after you've pressed  $r/P$  in step 3, press MODE•MONO/ST ISS to select the position that most decreases the noise.

Use these buttons for additional operations

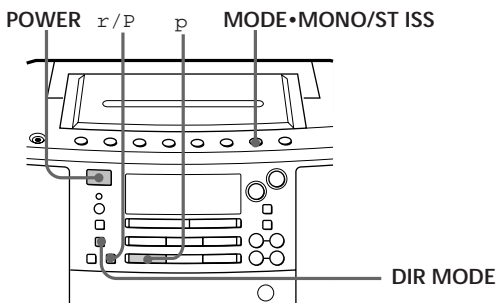

To	Press
Stop recording	p
Pause recording	$r/P$ Press the button again to resume recording.
Turn on/off the player	POWER

To erase a recording, proceed as follows:

- 1 Insert a tape you want to erase its recording into tape deck and press p on the tape section.
- 2 On the player: press  $r/P$  and then ( .  
On the remote: While keeping  $r/P$  pressed, press ( on the tape section.

# Using the display

You can check information about the CD using the display.

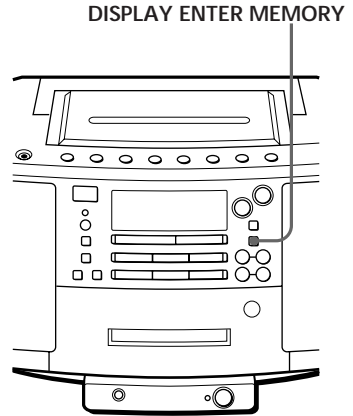

## Checking the total track number and playing time

Press DISPLAY ENTER MEMORY in stop mode.

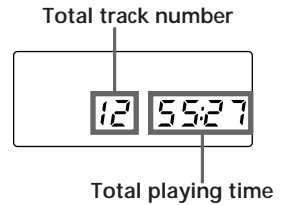

## Checking the remaining time

Press DISPLAY ENTER MEMORY while playing a CD.

To display	Press DISPLAY ENTER MEMORY
The current track number and the remaining time on the current track*	Once
Remaining time on the CD and the number of tracks left	Twice
The current track number and playing time	Three times

\* For a track whose number is more than 20 the remaining time appears as "--:--".

# Locating a specific track

You can quickly locate any track using the number buttons. You can also find a specific point in a track while playing a CD.

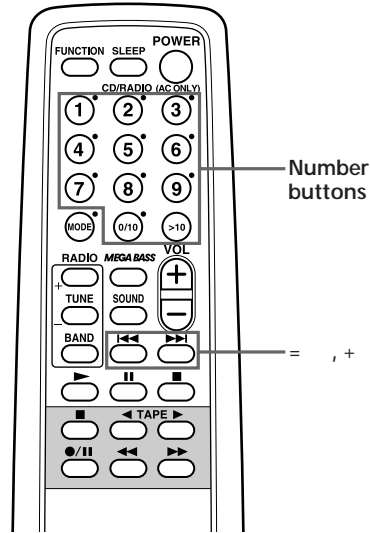

### Note

You cannot locate a specific track if “SHUF” or “PGM” is lit in the display. Turn off the indication by pressing **P** on the CD section.

### Tip

When you locate a track numbered over 10, press >10 first, then the corresponding number buttons.  
 Example:  
 To play track number 23, press >10 first, then 2 and 3.

To locate	Press
a specific track directly	number button of the track.
a point while listening to the sound	= or + while playing and hold down until you find the point.
a point while observing the display	= or + in pause and hold down until you find the point.

# Playing tracks repeatedly

## (Repeat Play)

You can play tracks repeatedly in normal, shuffle or program play modes (see pages 16 - 18.).

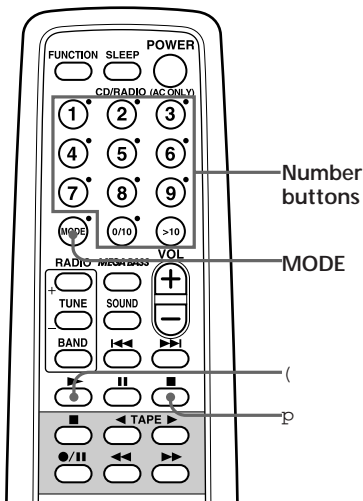

### Note

When you repeat a single track or all the tracks, make sure neither “SHUF” nor “PGM” is lit in the display. If either is lit, turn it off by pressing  $\text{p}$  on the CD section.

### On the player

- Use MODE•MONO/ST ISS to select “REP 1”, “REP ALL”, “REP” “SHUF” or “REP” “PGM”.
- Use = or + to select the track that you want, and then press  $\wedge$ .

- 1 Press  $\text{p}$  on the CD section. “Cd” appears in the display.
- 2 Proceed as follows.

To repeat	Do this
a single track	1 Press MODE until “REP 1” appears. 2 Press the number buttons to select the track that you want to repeat.
all the tracks	1 Press MODE until “REP ALL” appears. 2 Press ( on the CD section.
tracks in random order	1 Press MODE until “REP” “SHUF” appears. 2 Press ( on the CD section.
programmed tracks	1 Start program play. (See pages 17 and 18.) 2 Press MODE until “REP” “PGM” appears. 3 Press ( on the CD section.

### To cancel Repeat Play

Press MODE until “REP” disappears from the display.

# Playing a single track

## (Single Track Play)

You can play a single track once, and stop the player automatically.

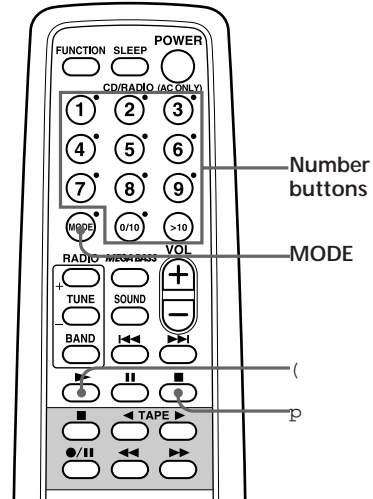

### On the player

- Use **MODE**•**MONO**/**ST ISS** to select "1TRACK".
- Use **=** or **+** to select the track that you want, and then press **^**.

- 1** Press **p** on the CD section.  
"Cd" appears in the display.
- 2** Press **MODE** until "1TRACK" appears in the display.
- 3** Press the number buttons to select the track you want to play.

### To cancel Single Track Play

Press **MODE** until "1TRACK" disappears from the display.

# Playing tracks in random order

## (Shuffle Play)

You can play tracks in random order.

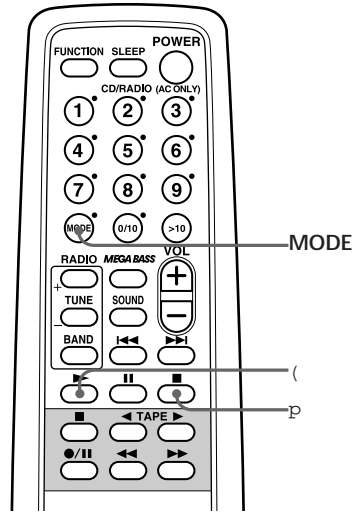

### On the player

Use MODE•MONO/  
ST ISS to select  
“SHUF”.

- 1** Press **P** on the CD section.  
“Cd” appears in the display.
- 2** Press **MODE** until “SHUF” appears in the display.
- 3** Press **(** on the CD section to start shuffle play.

### To cancel Shuffle Play

Press **MODE** until “SHUF” disappears from the display.



# Creating your own program

## (Program Play)

While listening to the CD, you can select the track you want and arrange the playing order of up to 20 tracks on a CD.

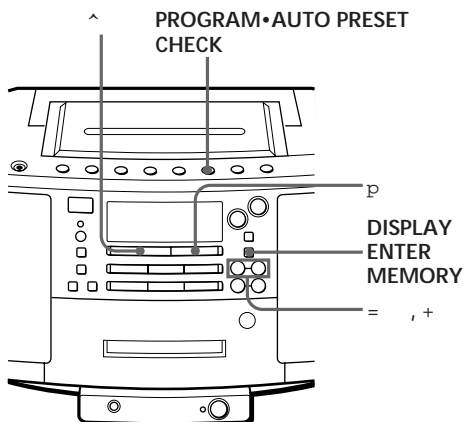

### Tips

- If you made a mistake, press CANCEL and re-enter the track number by pressing = or + and press DISPLAY ENTER MEMORY.
- You can also create a program in stop mode.

### Note

When you program a track from the CD having more than 20 tracks:

If you program a track whose track number is more than 20, “- :- -” is displayed instead of the total programmed time.

- 1 Press  $\wedge$  to start play.
- 2 Press PROGRAM•AUTO PRESET•CHECK until “PGM” appears in the display.
- 3 Press = or + to select the track you want to program, and press DISPLAY ENTER MEMORY. Repeat this step.

Total programmed time  
(displayed for about 2 seconds)

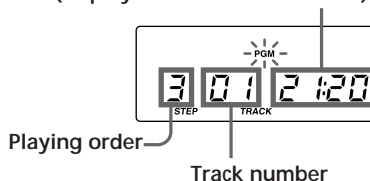

- 4 Press p on the CD section.
- 5 Press  $\wedge$  to start program play.

continued

## Creating your own program (Program Play) (continued)

### Tips

- If the program play is finished, the program is saved. You can play the same program again by pressing  $\wedge$ .
- If you open the CD compartment, the program is erased.
- You can record your own program.
  - 1 After you've created the program, insert a blank tape into the tape compartment.
  - 2 Press  $r/P$  and then ( to start recording. Press  $\wedge$  to start playing the program play.

### To cancel Program Play

Press **MODE**•**MONO/ST** until "PGM" disappears from the display.

### To check the order of tracks before play

Press **PROGRAM**•**AUTO PRESET**•**CHECK** in stop mode until "CHECK" appears in the display.

As you press = or + , the track number appears in the programmed order.

### To change the current program

Change before starting the program play.

To	Do this
Erase the last track in the program	<ol style="list-style-type: none"><li>1 Press <b>CANCEL</b>. Every time you press the button, the last track in the program is cleared.</li><li>2 Re-enter the track numbers using = or + and <b>DISPLAY ENTER MEMORY</b>.</li></ol>
Change the whole program completely	<ol style="list-style-type: none"><li>1 Press <b>p</b> on the CD section to erase the whole program.</li><li>2 Create a new program following the programming procedure.</li></ol>

# Presetting radio stations

You can store radio stations into the player's memory. You can preset up to 20 radio stations, 10 for FM and AM in any order.

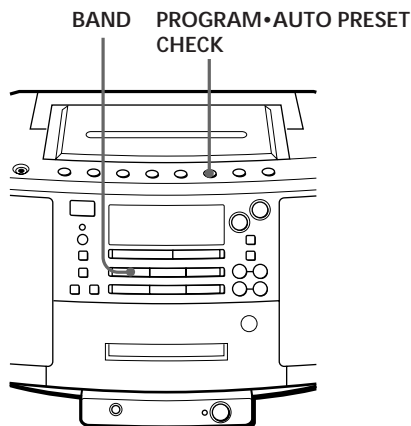

- 1** Press **BAND** until the band you want appears in the display.
- 2** Hold down **PROGRAM•AUTO PRESET•CHECK** until “AUTO” appears in the display.

The stations are stored in memory from the lower frequencies unless a station has a weak signal.

### If a station cannot be preset automatically

You need to preset a station with a weak signal manually. Also, when you want to replace a preset station with a new one, proceed as follows:

On the remote:

- 1** Press **BAND** until the band you want appears in the display.
- 2** Press **TUNE/TIME SET + or -** until you tune in a station you want.
- 3** Hold down the number buttons that you want to preset the new station for about 2 seconds.

The new station replaces the old one.

On the player

- 1** Press **BAND** to tune in the band you want.
- 2** Hold down **DISPLAY ENTER MEMORY** for about 2 seconds.
- 3** Press **PRESET + or -** to display the preset number you want.
- 4** Press **DISPLAY ENTER MEMORY**.
- 5** Press **TUNE/TIME SET + or -** to tune in a station you want.
- 6** Press **DISPLAY ENTER MEMORY**.

# Playing preset radio stations

Once you've preset the stations, use the number buttons on the remote or PRESET +, - on the player to tune in your favorite stations.

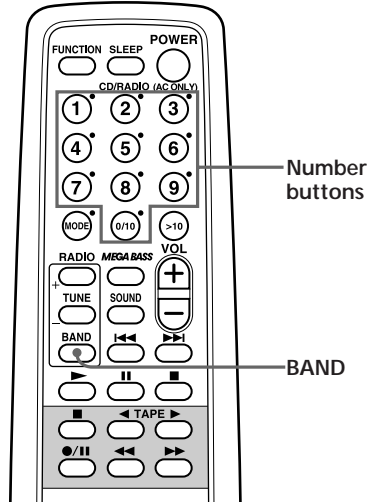

## On the player

Use PRESET + or - to display the preset number you want.

- 1 Press BAND to tune in the band you want.
- 2 Press the number buttons to display the preset number of the station you want.

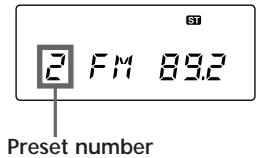

# Finding the beginning of a track

The player detects a blank between the tracks, and locates the beginning of the next/following track.

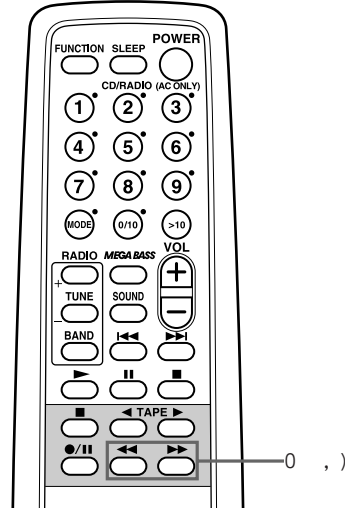

## Notes

- If a soft sound like pianissimo continues for some seconds in a track, the player may start to play as the next track.
- If you press the ) or 0 when there is no sound in the track, this function does not operate correctly.
- To find the beginning of a track correctly, a blank of approx. 4 seconds is necessary.

While playing a tape, press ) or 0 .

Playing side	The beginning of the next track	The beginning of the current track
Front side ( ( ) )	)	0
Reverse side (9 )	0	)

The tape is wound or rewound to the beginning of the next or current track, and play will start automatically.

# Recording the tracks on CD by specifying the tape length

There are three options in editorial recording:

- Recording all the tracks in the original CD order. (EDIT ALL)
- Recording programmed tracks (EDIT PGM)
- Recording a single track you have selected (EDIT 1TRACK)

## Tips

- You can edit a CD having 20 tracks or fewer.
- We recommend that you use AC power as the power source for optimum recording quality.

## Note

Do not open the CD compartment while editing; the settings for recording will be erased. If you do, start from step 1 again.

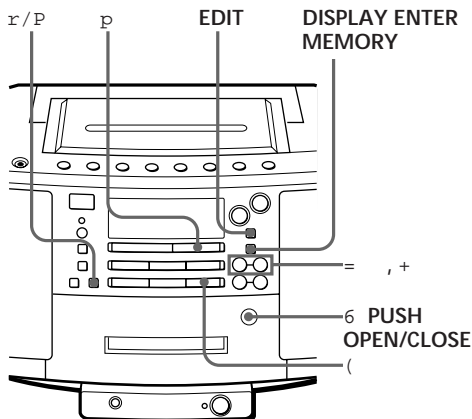

## Recording all the tracks on CD (EDIT ALL)

Approximately the first half of the CD will be recorded on one side of the tape, and the second half will be recorded on the other side, without reversing the tape in the middle of a track. According to the tape you use, you can set the total recording time.

- 1 Press **P** on the CD section until “Cd” appears in the display.
- 2 Press **EDIT** to display “E-ALL”.

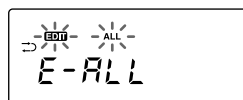

The tape length (unit: 2 minutes, up to 98 minutes) you need to record the whole CD appears in the display.



Example: The total tape length needed to record the entire CD is “26” minutes. The maximum recording time for each side is 13 minutes.

Track Nos.:	1	2	3	4	5	6	7
Length: (minutes)	01:20	02:30	03:40	04:50	05:10	04:20	01:30
	Side A (12:20)				Side B (11:00)		

**Tip**

To check the total recording time on the front side and the reverse side:  
 Press DISPLAY ENTER MEMORY before starting recording. Each time you press the button, the display changes as follows:  
 “total recording time on the front side” n  
 “total recording time on the reverse side” n  
 “the total track number and the tape length you need to record the whole CD.”

- 3** To change the recording time, press = or + .  
 If you do not change the recording time, skip to step 5.



**Example:** If you input “40” minutes for the recording time, the maximum recording time for each side is 20 minutes.

Track Nos.:	1	2	3	4	5	6	7
Length:	01:20	02:30	03:40	04:50	05:10	04:20	01:30
(minutes)	Side A (17:30)					Side B (5:40)	

- 4** Press DISPLAY ENTER MEMORY.  
**5** Insert a blank tape into the tape compartment.  
**6** Press r/P and then ( .

Recording will start on the front side automatically.



## Recording the tracks on CD by specifying the tape length (continued)

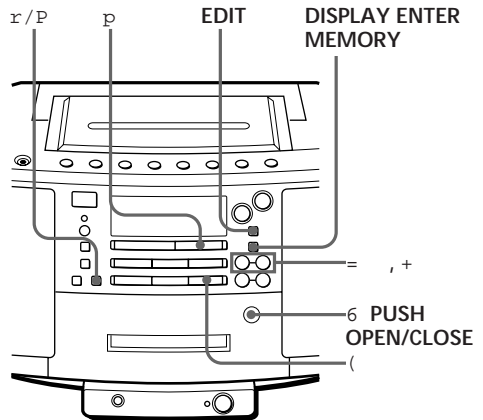

### Note

Do not open the CD compartment while editing; the settings for recording will be erased. If you do, start from step 1 again.

### Recording programed tracks (EDIT PGM)

The first half of the programed tracks will be recorded on one side of the tape, and the second half will be recorded on the other side. According to the tape you use, you can set the total recording time.

- 1 Press **p** on the CD section until “Cd” appears in the display.
- 2 Press **EDIT** to display “E-PGM”.





**Note**

When "--" is displayed as the tape length, the total recording time of the programmed tracks exceeds 98 minutes. Start from step 1 again.

**Tips**

- If you made a mistake, press CANCEL. The track programmed last will be cleared. Re-program it.
- To check the order of tracks, press PROGRAM•AUTO PRESET•CHECK in stop mode until "CHECK" appears in the display. Press = or + to display the track number in the programmed order.
- To check the total recording time on the front side and the reverse side:  
Press DISPLAY ENTER MEMORY before starting recording. Each time you press the button, the display changes as follows: "total recording time on the front side" n "total recording time on the reverse side" n "total track number and the tape length you need to record the whole CD."

- 3** Press = or + to select the track you want to program, and press DISPLAY ENTER MEMORY.

The total number of programmed tracks and the minimum tape length (unit: 2 minutes, up to 98 minutes) you need to record the programmed tracks appear in the display.



- 4** Repeat step 3.
- 5** To change the recording time, press DISPLAY ENTER MEMORY. If you do not change the recording time, skip to step 7.

Tape length flashes.



- 6** Press = or + to change the recording time and press DISPLAY ENTER MEMORY.



- 7** Insert a blank tape into the tape compartment.
- 8** Press r/P and then ( .

Recording will start on the front side automatically. The tracks are recorded in the programmed order.



## Recording the tracks on CD by specifying the tape length (continued)

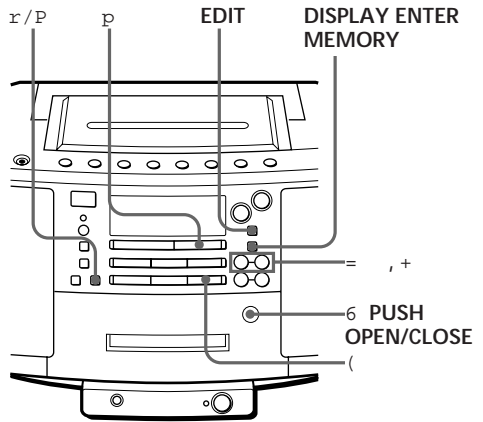

### Recording a single track (EDIT 1TRACK)

EDIT 1TRACK is useful to record the first track of single CD, and to record a track from a number of different CDs. Recorded on the both sides mode “↔” is automatically selected.

- 1 Insert a blank tape into the tape compartment.
- 2 Press **p** on the CD section until “Cd” appears in the display.
- 3 Press **EDIT** to display “E-1”.

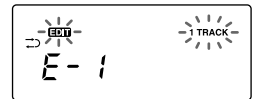

- 4 Press = or + to select the track you want to program.
- 5 Press  $\tau/P$  and press TAPE( to record on the front side or TAPE9 to record on the reverse side.

Recording will start for the selected track.

When recording of the track is finished, the CD player and the cassette deck stop. The total number of tracks recorded and the total recording time appear in the display.

When you record another track, repeat steps 4 and 5, or change the source CD and repeat steps 4 and 5.



# Setting the clock

“--:--” indication appears in the display until you set the clock.

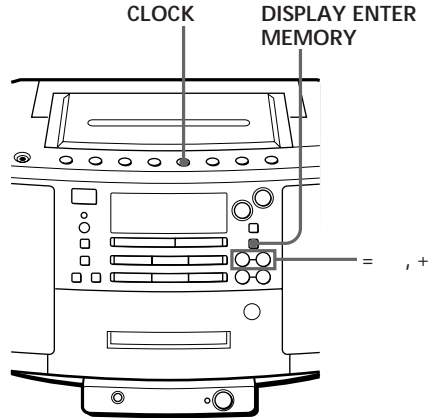

## Tips

- The time display system of this player is the 12-hour system.
- When you use the AC power cord, “:” flashes as long as the clock goes.

Before you begin, connect to the power source (see pages 34 - 35.)

**1** Press and hold **CLOCK** until the hour digit flashes.



**2** Set the clock.

1 Press = or + to set the hour and press **DISPLAY ENTER MEMORY**.



2 Press = or + to set the minutes.

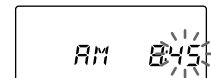



**3** Press **DISPLAY ENTER MEMORY**.

The clock starts from 00 seconds.

# Waking up to music

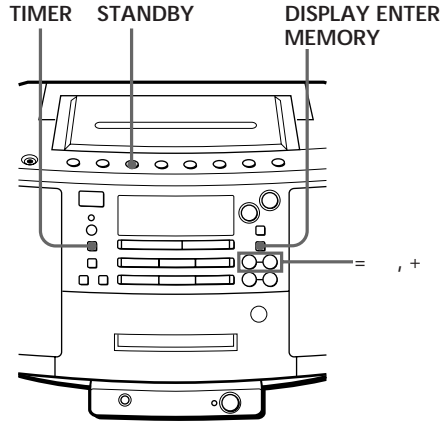
You can wake up to music or a radio program at a preset time. Make sure you have set the clock (“Setting the clock” on page 28).



Before you begin, make sure the  (clock) indication is not lit in the display. If it is lit, press STANDBY.

## 1 Prepare the music source you want to play.

Source	Do this
Cd	Insert a CD.
RADiO	Tune in a station.
TAPE	Insert a tape.
LINE	Turn on the equipment connected to LINE.

## 2 Press TIMER to display the indication.

Do the following operations by checking the display.



## 3 Press = or + until the music source you want to play (“Cd”, “TAPE”, “RADiO” or “LINE”) appears in the display, and press DISPLAY ENTER MEMORY.

continued

## Waking up to music (continued)

### Tip

If you made a mistake, press CANCEL. The setting entered last will be cleared. Re-enter it.

### Tips

- To exit the standby mode, press STANDBY to make the  $\tau$  indication disappear.
- The preset settings remain until you reset them.
- The display window does not light while the waking up timer is on.

### 4 Set the timer to the hour and the minutes you want the music to go on.

- 1 Press = or + to set the hour and press DISPLAY ENTER MEMORY.



- 2 Press = or + to set the minutes, and press DISPLAY ENTER MEMORY.

### 5 Set the timer to the hour and the minutes you want the music to go off (Do as step 4.).

### 6 Press = or + to set the volume you want, and press DISPLAY ENTER MEMORY.



### 7 Press STANDBY.

The  $\tau$  indication lights up and the power goes off; the player enters the standby mode.

At the preset time, the power will go on and music will play. Then the power will go off at the preset time, and the player will enter the standby mode again.

### To check/change the waking up timer settings

Press TIMER, then DISPLAY ENTER MEMORY. Each time you press DISPLAY ENTER MEMORY, a stored setting is displayed in the set order. To change the setting, display the setting you want to change and re-enter it.

### To use the player before a timer playback starts

If you turn on the player, you can use it as usual ( in case of the radio, if you listen to the station which is different from the one you tuned in step 1 on page 29, you will hear that station at the preset time.) Turn off the player before the preset time.

### To stop play

Turn off the power.

# Falling asleep to music

You can set the player to turn off automatically after 10, 20, 30, 60, 90 and 120 minutes, allowing you to fall asleep while listening to music.

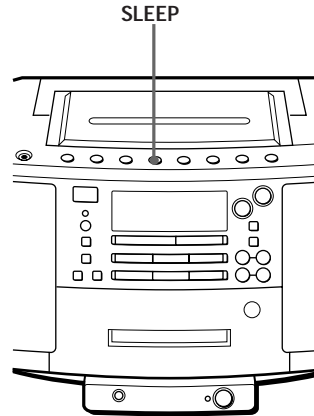

## Tips

- The display window does not light while the sleeping timer is on.
- You can combine the waking up timer with the sleeping timer. Set the waking up timer first (see page 29), turn on the power, and then set the sleeping timer.
- You can prepare the different music for the waking up timer and the sleeping timer. However, you cannot, store different radio stations.
- You can set different volume for the waking up timer and the sleeping timer. For instance, you can sleep at lower volume and wake up at higher volume.

- 1 Play the music source you want.
- 2 Press SLEEP to display "SLEEP."
- 3 Press SLEEP to select the minutes when the player goes off automatically.

Each time you press the button, the indication changes as follows: "10" n "20" n "30" n "60" n "90" n "120" n no indication.



If 4 seconds have passed after you pressed SLEEP, the minutes in the display are stored in memory.

When the preset time has passed, music stops and the player goes off automatically.

## To cancel the sleep function

Press SLEEP to make "SLEEP" disappear from the display.

## To change the preset time

Do the steps 2 and 3 again.

# Timer-recording radio programs

You can set timer to record the radio at a certain time. You can also record the sound of the component connected to the LINE IN jack, using the timer. Make sure you have set the clock (see “Setting the clock” on page 28).

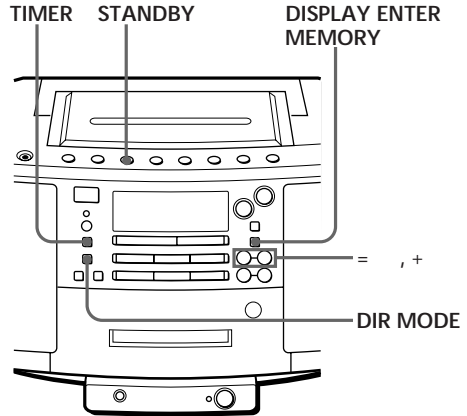

## Note

You cannot preset recording timer and waking up timer (page 29) at the same time.

## Tips

- We recommend that you use AC power as the power source for optimum recording quality.
- When you receive the AM program in step 1, press  $r/P$  to check if the noise is heard. If so, press MODE•MONO/ST ISS to select the position that most decreases the noise.

Before you begin, make sure the  $\tau$  (clock) indication is not lit in the display. If it is lit, press STANDBY.

**1** Tune in the radio station and insert a blank tape into the tape compartment with the side you want to record on facing forward.

**2** Press DIR MODE to select recording direction of the tape.

	display
One side	$\Rightarrow$
Both sides	$\Leftrightarrow$

**3** Press TIMER to display the  $\tau$  indication.

Do the following operations by checking the display window.



**4** Press = or + to display “RADiO” “REC,” and press DISPLAY ENTER MEMORY.

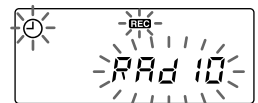



**Tip**

If you made a mistake, press CANCEL. The setting entered last will be cleared. Re-enter it.

**Tips**

- To exit the standby mode, press STANDBY twice to make the  $\tau$  indication disappear.
- The preset settings remain until you reset them.
- When you select both sides recording, the recording will stop after the both sides recording finishes so that accidental recording will not be made.
- The display window does not light while the recording timer is on.

**5** Set the timer to the hour and the minutes you want to start recording.

- 1 Press = or + to set the hour and press DISPLAY ENTER MEMORY.

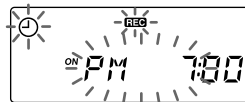

- 2 Press = or + to set the minutes, and press DISPLAY ENTER MEMORY.

**6** Set the timer to the hour and the minutes you want to stop recording. (Do as step 5.)

**7** Press = or + to set the volume you want, and press DISPLAY ENTER MEMORY.



**8** Press STANDBY.

The power goes off and the player enters the standby mode. The  $\tau$  indication and the recording side of the tape (front side ( ) or reverse side ( )) appear in the display. To change the recording side, press STANDBY again.

At the preset time, the power will go on and the recording will start. Then the power will go off at the preset time, and the player will enter the standby mode again.

**To check/change the recording timer settings**

Press TIMER, then DISPLAY ENTER MEMORY. Each time you press DISPLAY ENTER MEMORY, a stored setting is displayed in the set order. To change the setting, display the setting you want to change and re-enter it.

**To use the player before a timer-recording starts**

If you turn on the player, you can use it as usual. Before the preset time, tune in the station you want to record and turn off the power.

**To stop timer-recording**

Turn off the power.

# Choosing the power sources

You can use the AC power or batteries as a power source.

Use the AC power source whenever you record since recording consumes much power.

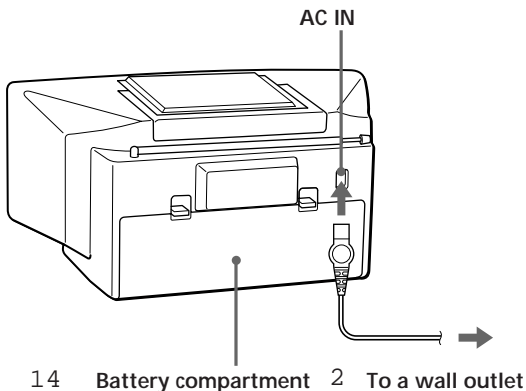

## Note

Be sure to turn off the power of the player before connecting/disconnecting the AC power cord or removing/inserting batteries.

### 1 Inserting the back-up batteries

Insert four size AA (R6) batteries (not supplied) into the battery compartment. These batteries work to save the memory data.

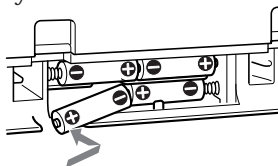

Insert four size AA (R6) batteries (not supplied)

### Replacing batteries

With normal use, the back-up batteries should last for about six months when the player is operated on batteries. When the time display dims or when the timer function is disabled, replace all the batteries with new ones. To save the preset settings, replace the batteries with the AC power cord connected.

## Tip

The sound quality may be changed depending on the polarity of the plug. Change the direction of inserting the plug and check the sound quality.

### 2 Connecting the AC power cord

Insert one end of the supplied AC power cord to the AC IN socket located at the rear of the player, and the other end to the wall outlet.

### 3 Inserting batteries into the remote

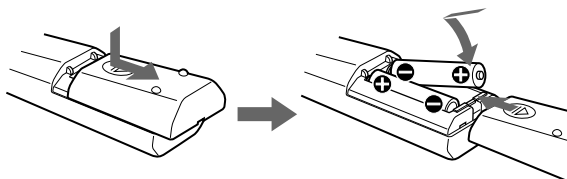

Insert two size AA (R6) batteries (not supplied)

#### Replacing batteries

With normal use, the batteries should last for about six months. When the remote no longer operates the player, replace all the batteries with new ones.

#### Notes

- When you insert or remove the batteries, disconnect the connecting cords and cables to prevent damaging them.
- When you operate the player on batteries, the backlight in the display does not light.
- When you operate the player on batteries, you can't turn on the player using the remote.

### 4 Using the player on batteries

Insert eight size D (R20) batteries (not supplied) into the battery compartment.

To use the player on batteries, disconnect the AC power cord from the player.

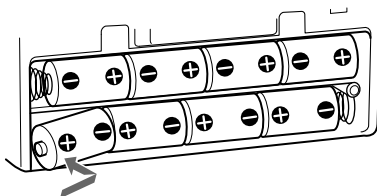

Insert eight size D (R20) batteries (not supplied)

#### Replacing batteries

When the OPR/BATT indicator dims or when the player stops operating, replace all the batteries with new ones.

# Connecting optional components

You can record a CD on a MiniDisc or enjoy the sound from a VCR, TV or MiniDisc player/recorder through the speakers of this player.

Be sure to turn off the power of each component before making connections.

For details, refer to the instruction manual of the component to be connected.

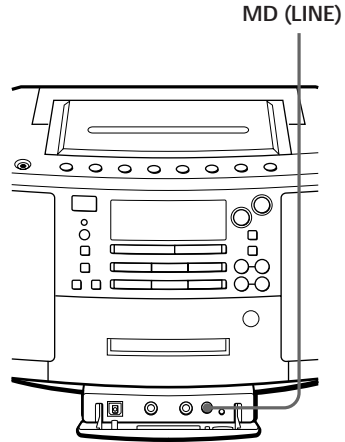

## Note

Connect the cables firmly to avoid any malfunction.

## Recording a CD on a MiniDisc recorder and DAT recorder

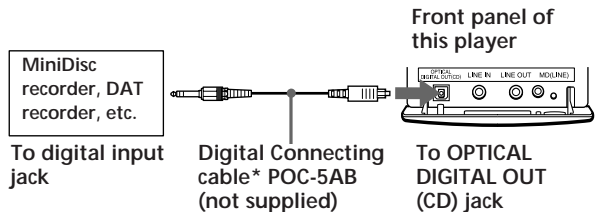

\* Select a connecting cable depending on the type of the digital input jack of the recorder to be connected. For details, refer to the instruction manual of the component to be connected. The OPTICAL DIGITAL OUT (CD) jack of this unit is square-shaped jack.

The type of the jack of the component to be connected	Model number of the connecting cable
Optical miniplug (MiniDisc recorder, etc.)	POC-5AB
L-type 7-pin connector (DAT recorder, etc.)	POC-DA12P
Square-shaped optical connector (MiniDisc recorder, DAT recorder, etc.)	POC-10A

**Tip**

To record a track from a number of different CDs, EDIT 1TRACK is useful (page 26).

- 1 Make connections.
- 2 Turn on this player and the connected component.
- 3 Do steps 2 through 5 on pages 26 and 27.
- 4 Make the connected component ready for recording.
- 5 Start playing a CD on this player.

- 1 Connect the OPTICAL DIGITAL OUT (CD) jack of this player with the digital input jack of the MiniDisc recorder or other component using the digital connecting cable (not supplied) .
- 2 Turn on the power of this player and the connected component.
- 3 Make the connected component ready for recording.
- 4 Start playing a CD on this player.

**Listening to TV, VCR and MiniDisc player/recorder**

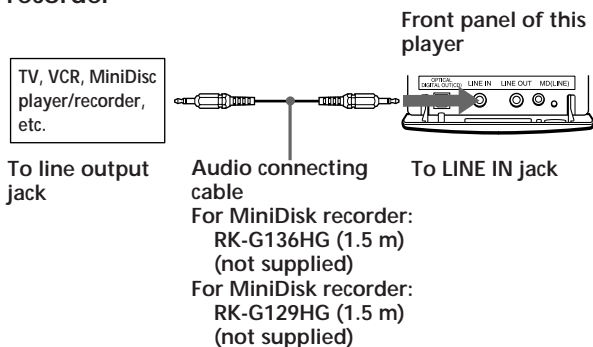

**Tip**

You can record the sound of the connected component. Insert a blank tape into the tape compartment, and press  $\tau$  / P then TAPE ( . (Page 11)

- 1 Connect the LINE IN jack of this player with the line output jack of the MiniDisk player or other component using the audio connecting cable (not supplied) .
- 2 Turn on the power of this player and the connected component.
- 3 Press MD (LINE) and start playing sound on the connected component.  
The sound from the connected component is output from the speakers.

continued

## Connecting optional components (continued)

### Notes

- As long as “Cd” appears in the display, the optical digital output jack is in operation and the jack lights even if the CD is in stop mode.
- If you play a CD-ROM that is not for audio use, noise may be heard.

### Listening through the speakers of other audio equipment

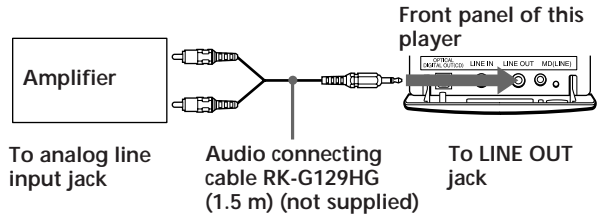

- 1** Connect the LINE OUT jack of this player with the analog line input jack of the amplifier using the audio connecting cable (not supplied) .
- 2** Turn on the power of this player and the amplifier and start playing sound on this player.

# Selecting the audio emphasis

(Sound Mode/MEGA BASS)

You can adjust the audio emphasis of the sound you are listening to.

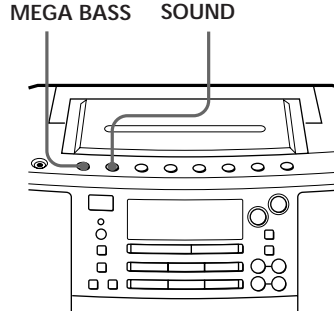

## Selecting the sound characteristic

Press SOUND to select the audio emphasis you want. Each time the button is pressed, the display changes.

Choose	To get
	<b>For rock'n'roll music:</b> powerful, clean sounds, emphasizing low and high range audio.
	<b>For popular music:</b> light, bright sounds emphasizing high and middle range audio
	<b>For jazz:</b> percussive sounds, emphasizing bass audio.
	<b>For vocals:</b> the presence of vocals, stressing middle range audio
	<b>For classical music:</b> the whole dynamic range for music

## Reinforcing the bass sound

Press MEGA BASS.

“MEGA BASS” appears in the display. To return to normal sound, press the button again.

# Precautions

## On safety

- As the laser beam used in the CD player section is harmful to the eyes, do not attempt to disassemble the casing. Refer servicing to qualified personnel only.
- Should any solid object or liquid fall into the player, unplug the player, and have it checked by qualified personnel before operating it any further.

## On power sources

- For AC operation use the supplied AC power cord; do not use any other type.
- The player is not disconnected from the AC power source (mains) as long as it is connected to the wall outlet, even if the player itself has been turned off.
- Unplug the player from the wall outlet when it is not to be used for an extended period of time.
- For battery operation, use eight size D (R20) batteries.
- When the batteries are not to be used, remove them to avoid damage that can be caused by battery leakage or corrosion.
- The nameplate indicating operating voltage, power consumption, etc. is located at the bottom.

## On placement

- Do not leave the player in a location near heat sources, or in a place subject to direct sunlight, excessive dust or mechanical shock.
- Do not place the player on an inclined or unstable place.
- Do not place anything within 10 mm of the side of the cabinet. The ventilation holes must be unobstructed for the player to operate properly and prolong the life of its components.
- If the player is left in a car parked in the sun, be sure to choose a location in the car where the player will not be subjected to the direct rays of the sun.
- Since a strong magnet is used for the speakers, keep personal credit cards using magnetic coding or spring-wound watches away from the player to prevent possible damage from the magnet.

## On operation

- If the player is brought directly from a cold to a warm location, or is placed in a very damp room, moisture may condense on the lenses inside the CD player section. Should this occur, the player will not operate properly. In this case, remove the CD and wait about an hour for the moisture to evaporate.
- If the player has not been used for a long time, set it in the playback mode to warm it up for a few minutes before inserting a cassette.

If you have any questions or problems concerning your player, please consult your nearest Sony dealer.



## Notes on CDs

- Before playing, clean the CD with a cleaning cloth. Wipe the CD from the center out.



- Do not use solvents such as benzine, thinner, commercially available cleaners or anti-static spray intended for vinyl LPs.
- Do not expose the CD to direct sunlight or heat sources such as hot air ducts, nor leave it in a car parked in direct sunlight as there can be a considerable rise in temperature inside the car.
- Do not stick paper or sticker on the CD, nor scratch the surface of the CD.
- After playing, store the CD in its case.

If there is a scratch, dirt or fingerprints on the CD, it may cause tracking error.

## Notes on cassettes

- Break off the cassette tab from side A or B to prevent accidental recording. If you want to reuse the tape for recording, cover the broken tab with adhesive tape.

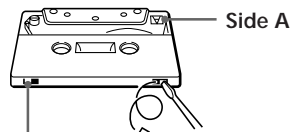

Tab for side B      Tab for side A

- Take care not to cover the detector slots on TYPE II (high position) or TYPE IV (metal) cassettes. If the slots are covered, the automatic tape selection system will not operate correctly.

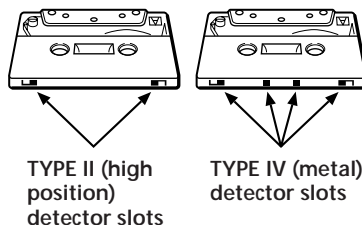

- The use of a cassette with more than 90 minutes of play time is not recommended except for long, continuous recording or playback.

# Troubleshooting

	Symptom	Remedy
General	There is no audio.	<ul style="list-style-type: none"> <li>• Press POWER to turn on the player.</li> <li>• Connect the AC power cord to the AC IN socket and a wall outlet securely.</li> <li>• Make sure the batteries are inserted correctly.</li> <li>• Replace all the batteries with new ones if they are weak.</li> <li>• Adjust the volume.</li> <li>• Unplug the headphones when listening through speakers.</li> </ul>
	The power is turned off automatically.	<ul style="list-style-type: none"> <li>• Replace all the batteries with new ones.</li> </ul>
	Unusual sound is heard. The sound is noisy, weak or has poor quality.	<ul style="list-style-type: none"> <li>• Replace all the batteries with new ones if they are weak.</li> </ul>
CD Player	The CD does not play.	<ul style="list-style-type: none"> <li>• Make sure that the CD compartment is closed.</li> </ul>
	“NO DISC“ lights in the display even when a CD is in place.	<ul style="list-style-type: none"> <li>• Place the CD with the label surface up.</li> <li>• Clean the CD.</li> <li>• Take out the CD and leave the CD compartment open for about an hour to dry moisture condensation.</li> <li>• Press <b>P</b> on the CD section to switch the function of the player to “Cd”.</li> </ul>
	The sound drops out.	<ul style="list-style-type: none"> <li>• Reduce the volume.</li> <li>• Clean the CD, or replace it if the CD is badly damaged</li> <li>• Place the player in a location free from vibration.</li> </ul>
	When listening to the CD, the TV or radio becomes noisy.	<ul style="list-style-type: none"> <li>• Move the player away from the TV or radio.</li> </ul>
Radio	The audio is not stereo.	<ul style="list-style-type: none"> <li>• Press MODE•MONO/ST ISS until “STEREO” appears.</li> </ul>
	The audio is weak or has poor quality.	<ul style="list-style-type: none"> <li>• Depending on the FM reception conditions, noise may be heard.</li> <li>• Replace all the batteries with new ones if they are weak.</li> <li>• Move the player away from the TV.</li> <li>• If you are using the remote while listening to AM radio, noise may be heard. This is unavoidable.</li> </ul>
	The picture of your TV becomes unstable.	<ul style="list-style-type: none"> <li>• If you are listening to an FM program near the TV with an indoor antenna, move the player away from the TV.</li> </ul>

	Symptom	Remedy
Tape Player	The tape does not move when you press an operation button.	<ul style="list-style-type: none"> <li>• Insert the tape properly and close the tape compartment securely.</li> <li>• Replace all the batteries with new ones.</li> </ul>
	The $r/P$ button does not function/The tape does not play.	<ul style="list-style-type: none"> <li>• Make sure the safety tab of the tape in the tape compartment is in place.</li> <li>• Press <math>P</math> on the TAPE section to switch the function of the player to "TAPE".</li> </ul>
	The tape does not erase completely.	<ul style="list-style-type: none"> <li>• Clean the erasing heads (see page 45.)</li> </ul>
	The tape does not record.	<ul style="list-style-type: none"> <li>• Make sure the tape is inserted properly.</li> <li>• Make sure the safety tab of the tape in the tape compartment is in place.</li> </ul>
	The audio is weak/The audio quality is poor.	<ul style="list-style-type: none"> <li>• Clean the heads, pinch rollers and capstans (See page 45).</li> <li>• Demagnetize the heads using a demagnetizer (see page 45).</li> </ul>
	The tape player cannot be paused during playback.	<ul style="list-style-type: none"> <li>• The tape player can be paused during recording only.</li> </ul>
	The sound is distorted.	<ul style="list-style-type: none"> <li>• The source which was recorded on TYPE IV (metal) tape using this unit is being played.  <math>n</math> Record on TYPE I (normal) or TYPE II (high position) tape and play.</li> </ul>
Timer	The timer does not operate.	<ul style="list-style-type: none"> <li>• Make sure the time on the clock is correct.</li> <li>• Replace all the batteries in the player including the back-up batteries with new ones if they are weak.</li> <li>• Check to see if the AC power had been cut off.</li> <li>• Make sure the tape has not wound to the end.</li> <li>• Make sure the <math>t</math> (clock) indication is displayed.</li> </ul>

continued

---

## Troubleshooting (continued)

	Symptom	Remedy
Remote	The remote does not function.	<ul style="list-style-type: none"><li>• Replace all the batteries in the remote with new ones if they are weak.</li><li>• Make sure that you are pointing the remote at the remote sensor on the player.</li><li>• Remove any obstacles in the path of the remote and the player.</li><li>• Make sure the remote sensor is not exposed to strong light such as direct sunlight or fluorescent lamp light.</li><li>• Move closer to the player when using the remote.</li></ul>

The player uses a built-in micro computer for its various operations. Due to change in power supply conditions, etc., operation may sometimes become unstable. After trying the above remedies, if the player still does not function properly, unplug the AC power cord and remove all the batteries. After all indications in the display disappear, plug the AC power cord and insert the batteries again. If the problem persists, please consult your nearest Sony dealer.

# Maintenance

## Cleaning the tape heads and tape path

Wipe the heads, the pinch rollers and the capstans with a cleaning swab slightly moistened with cleaning fluid or alcohol after every 10 hours of operation for optimum playback and recording quality. To make the best possible recording, however, we recommend that you clean all surfaces over which tape travels before each recording.

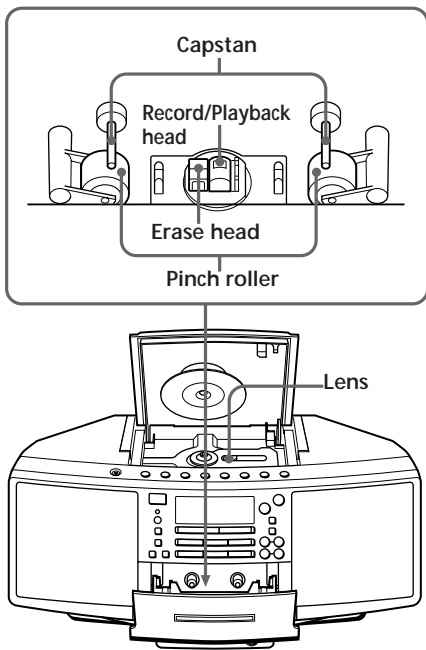

After cleaning, insert a tape when the areas cleaned are completely dry.

## Demagnetizing the tape heads

After 20 to 30 hours of use, enough residual magnetism will have built up on the tape heads to begin to cause loss of high frequency sound and hiss. At this time, you should demagnetize the heads and all metal parts in the tape path with a commercially available tape head demagnetizer.

## Cleaning the lens

If the lens becomes dirty, it may cause a skipping of sound during CD operation. Clean with a commercially available blower.

## Cleaning the cabinet

Clean the cabinet, panel and controls with a soft cloth slightly moistened with a mild detergent solution. Do not use any type of abrasive pad, scouring powder, or solvent, such as alcohol or benzine.

# Specifications

## AUDIO POWER SPECIFICATIONS

### POWER OUTPUT AND TOTAL HARMONIC DISTORTION

With 3-ohm loads, both channel driven from 150 - 15,000 Hz; rated 3 W per channel-minimum RMS power, with no more than 10 % total harmonic distortion in AC operation.

## Other Specifications

### CD player section

#### System

Compact disc digital audio system

#### Laser diode properties

Material: GaAlAs

Wave length: 780 nm

Emission duration: Continuous

Laser output: Less than 44.6  $\mu$ W (This output is the value measured at a distance of about 200 mm from the objective lens surface on the optical pick-up block with 7 mm aperture.)

#### Spindle speed

200 r/min (rpm) to 500 r/min (rpm) (CLV)

#### Number of channels

2

#### Frequency response

20 - 20,000 Hz +0/-1 dB

#### Wow and flutter

Below measurable limit

### Radio section

#### Frequency range

FM: 87.6 - 108 MHz

AM: 530 - 1,710 kHz

#### Aerials

FM: Telescopic aerial

AM: Built-in ferrite bar aerial

### Cassette-corder section

#### Recording system

4-track 2 channel stereo

#### Fast winding time

Approx. 120s (sec.) with Sony cassette C-60

#### Frequency response

TYPE I (normal): 50 - 15,000 Hz

## General

### Speaker

Full range: 8 cm (3 1/4 in.) dia., 3 ohms, cone type x 2

### Input

LINE IN jack (stereo minijack)

Minimum input level 250 mV

### Outputs

Headphones jack (stereo minijack)

For 16 - 68 ohms impedance headphones

LINE OUT jack (stereo minijack)

Rated output level 250 mV at load impedance 47 kilohms

OPTICAL DIGITAL OUT (CD) (optical output connector)

Wavelength: 630 - 690 nm

### Power output (excluding U.S. model)

4.5 W + 4.5 W (3 ohms at 10 % harmonic distortion in DC operation)

### Power requirements

For personal component system:

120 V AC, 60 Hz

12 V DC, 8 size D (R20 ) batteries

For memory back-up:

6 V DC, 4 size AA (R6) batteries

For remote commander:

3 V DC, 2 size AA (R6) batteries

### Power consumption

AC 25 W

### Battery life

For CD radio cassette-corder

---

#### FM recording

Sony R20P: approx. 6 h

Sony alkaline LR20: approx. 12 h

---

#### Tape playback

Sony R20P: approx. 3 h

Sony alkaline LR20: approx. 6 h

---

#### CD playback

Sony R20P: approx. 1.5 h

Sony alkaline LR20: approx. 3 h

### Dimensions (incl. projecting parts)

Approx. 416 × 198.5 × 246 mm (w/h/d)

(16 1/2 × 7 7/8 × 9 3/4 inches)

### Mass (incl. batteries)

Approx. 5.2 kg (11 lb. 7 oz)

### Supplied accessories

AC power cord (1)

Remote commander (1)

Design and specifications are subject to change without notice.

## Optional accessories

Sony MDR headphone series

---

# Index

## A

Audio emphasis 39

## B

Batteries

for memory 34

for player 35

for remote 35

## C

CD Player 12

Cleaning

cabinet 45

CD 41

lens 45

tape heads and path 45

Connecting

AC power cord 34

optional components  
36

Creating your own  
program 17

## D

Demagnetizing the tape  
heads 45

Display 12

## E, F, G, H

EDIT 1TRACK 26

EDIT ALL 22

EDIT PGM 24

## I, J, K

Improving broadcast  
reception 7

## L

Listening

through the speakers of  
other audio equi 38

to the radio 6

to the TV, VCR and  
MD player 37

Locating

a specific track 13

the beginning of a track  
21

## M, N, O

MEGA BASS 39

## P, Q

Playing

a CD 4

a single track 15

a tape 8

preset radio stations 20

tracks in random order  
16

tracks repeatedly 14

Presetting radio stations  
19

Program Play 17

## R

Radio stations

playing 20

presetting 19

Recording

a single track 26

all the tracks on CD 22

on a tape 10

on an MD or a DAT 36

programed tracks 24

timer-recording radio

programs 32

Repeat Play 14

## S

Selecting

audio emphasis 39

power sources 34

tracks 5, 13

Setting the clock 28

Setting up 34

Shuffle Play 16

SOUND 39

Sound mode 39

## T

Tape Player 21

Timer

falling asleep to music  
31

recording radio  
programs 32

waking up to music 29

Troubleshooting 42

## U, W, X, Y, Z

Using the display 12

