

Installation

Precautions

- Do not tamper with the four holes on the upper surface of the unit. They are for tuner adjustments to be made only by service technicians.
- Choose the installation location carefully so that the unit will not interfere with the driver while driving.
- Avoid installing the unit where it would be subject to high temperatures, such as from direct sunlight or hot air from the heater, or where it would be subject to dust, dirt or excessive vibration.
- Use only the supplied mounting hardware for a safe and secure installation.

Mounting angle adjustment

Adjust the mounting angle to less than 60°.

How to detach and attach the front panel

Before installing the unit, detach the front panel.

A To detach

Before detaching the front panel, be sure to press **OFF** first. Then press **OPEN** to open the front panel, then slide the front panel to the right side, and pull out the left side of the front panel.

B To attach

Place the hole **A** in the front panel onto the spindle **B** on the unit as illustrated, then push the left side in.

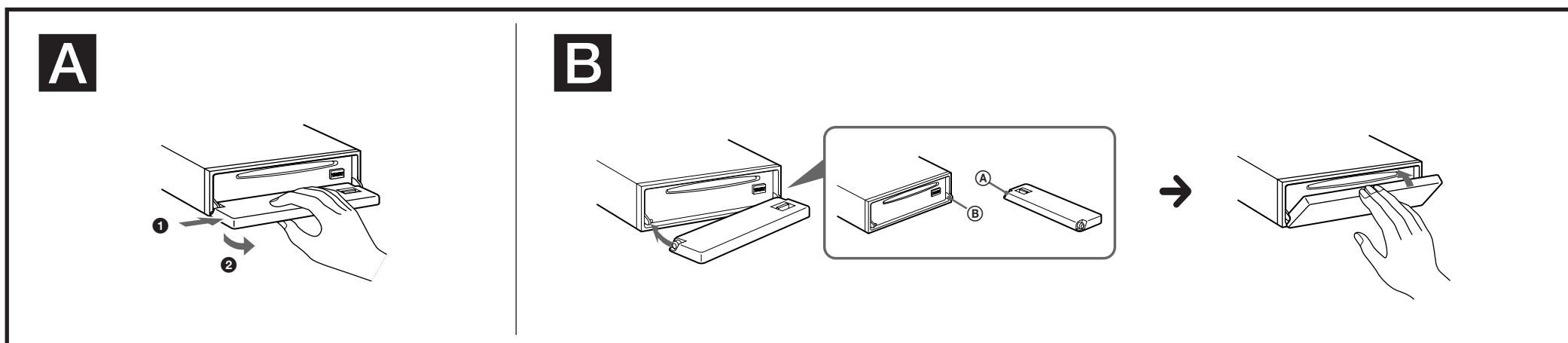

Mounting example

Installation in the dashboard

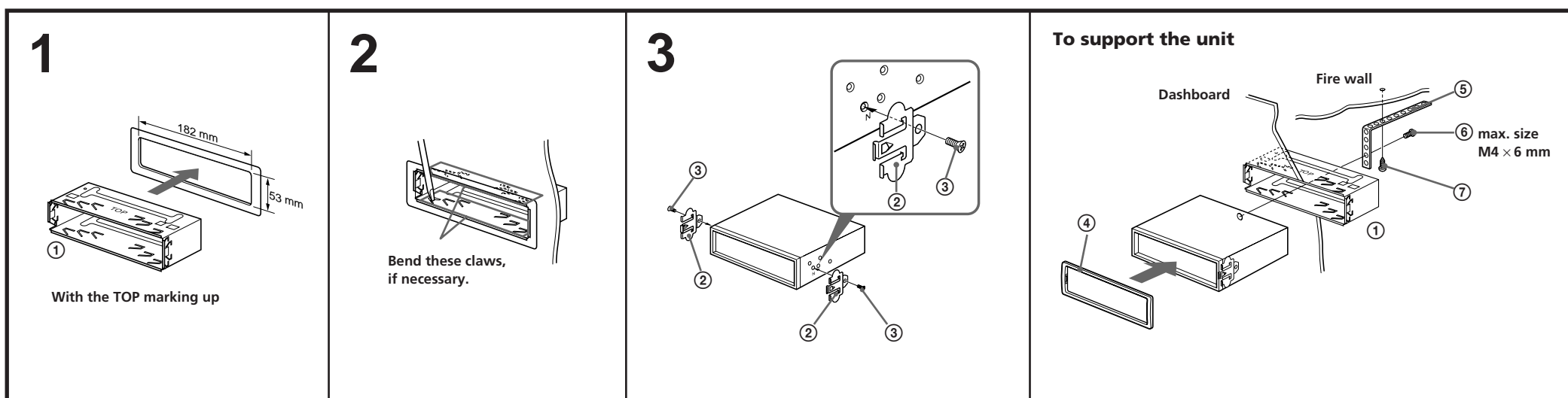

Mounting the unit in a Japanese car

You may not be able to install this unit in some makes of Japanese cars. In such a case, consult your Sony dealer.

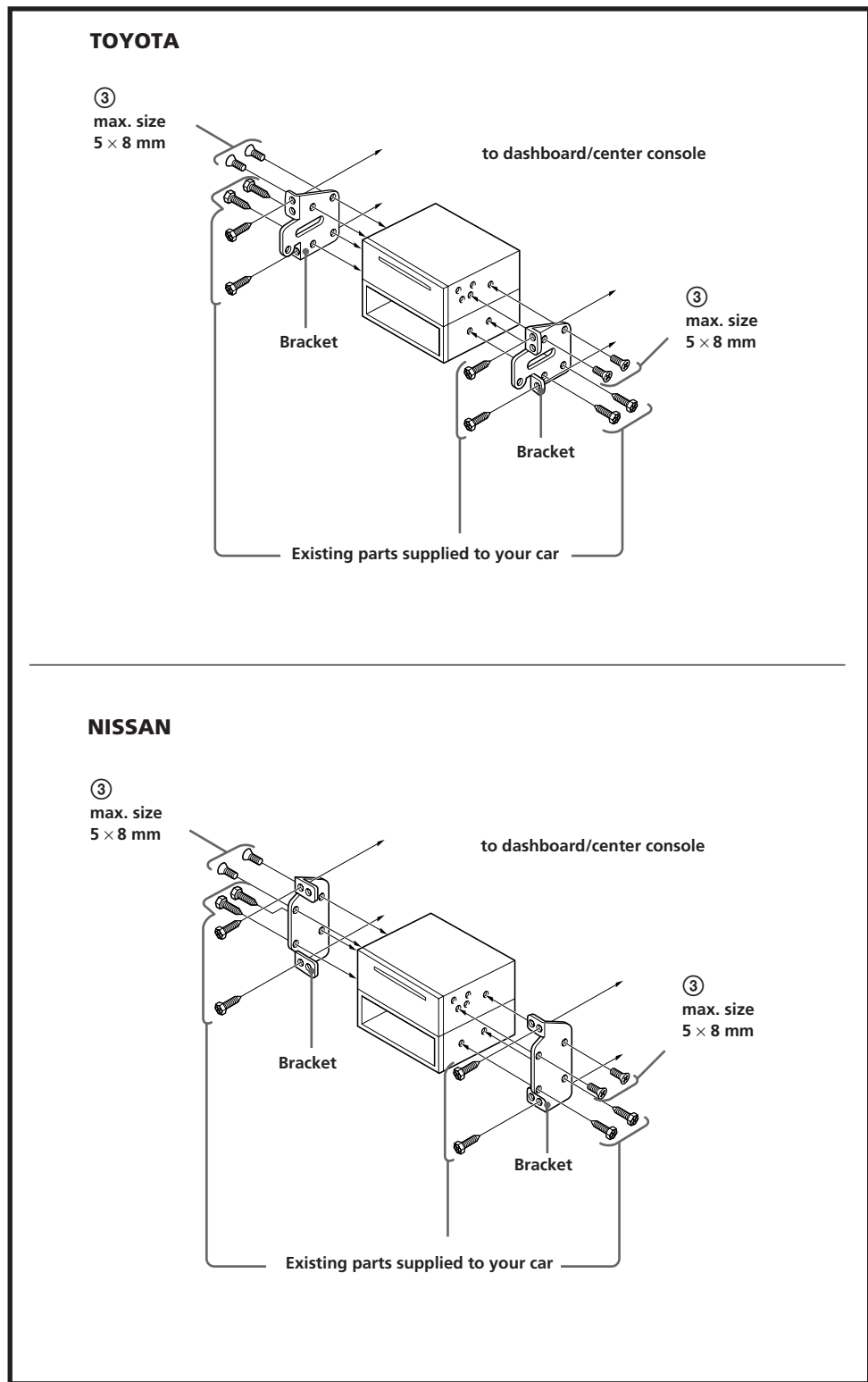

Note
To prevent malfunction, install only with the supplied screws ③.

**FM/AM
Compact Disc
Player**

Installation/Connections



CDX-C680

Sony Corporation © 1998 Printed in Japan

Parts for installation and connections

The numbers in the list are keyed to those in the instructions.

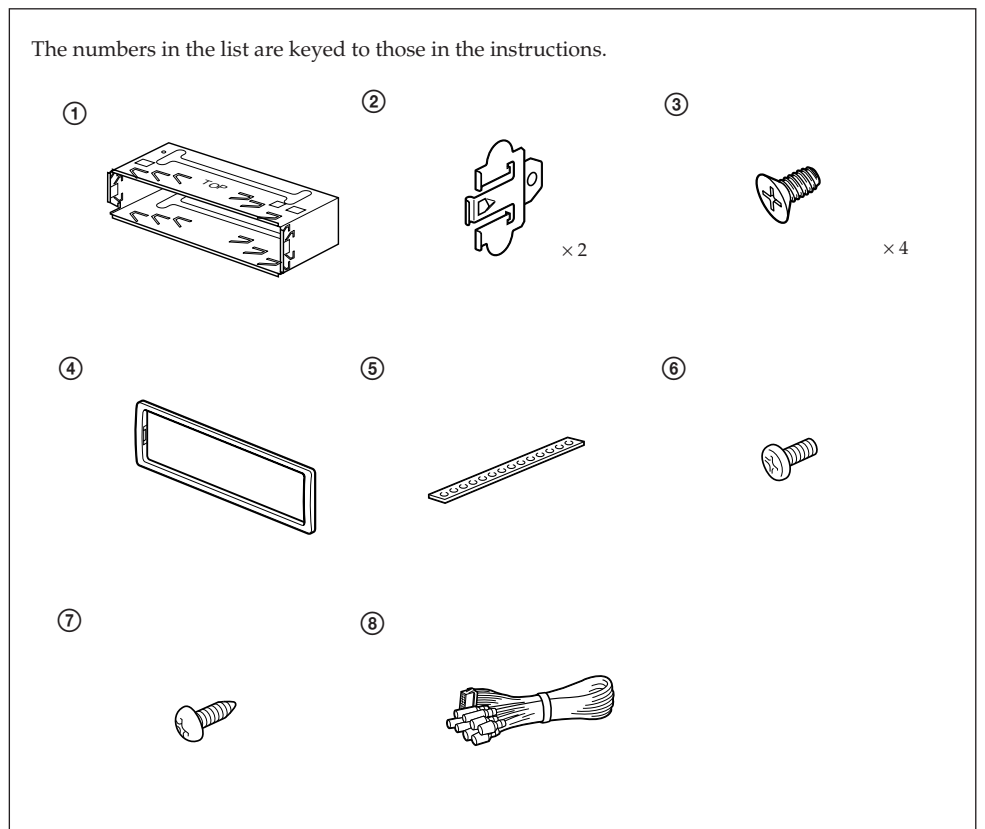

Caution

Cautionary notice for handling the bracket ①.
Handle the bracket carefully to avoid injuring your fingers.

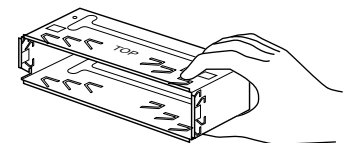

Connections

Caution

- This unit is designed for negative ground 12 V DC operation only.
- Before making connections, disconnect the ground terminal of the car battery to avoid short circuits.
- Connect the **yellow** and **red** power input leads only after all other leads have been connected.
- Be sure to connect the red power input lead to the positive 12 V power terminal which is energized when the ignition key is in the accessory position.
- **Run all ground wires to a common ground point.**
- Connect the yellow cord to a free car circuit rated higher than the unit's fuse rating. If you connect this unit in series with other stereo components, the car circuit they are connected to must be rated higher than the sum of the individual component's fuse rating. If there are no car circuits rated as high as the unit's fuse rating, connect the unit directly to the battery. If no car circuits are available for connecting this unit, connect the unit to a car circuit rated higher than the unit's fuse rating in such a way that if the unit blows its fuse, no other circuits will be cut off.
- The use of optical instruments with this product will increase eye hazard.

If your car has no accessory position on the ignition key switch — POWER SELECT switch

The illumination on the front panel is factory-set to be turned on even when the unit is not being played. However, this setting may cause some car battery wear **if your car has no accessory position on the ignition key switch**. To avoid this battery wear, **set the POWER SELECT switch located on the bottom of the unit to the **B** position, then press the reset button**. The illumination is reset to stay off while the unit is not being played.

Notes

- The caution alarm for the front panel is not activated when the POWER SELECT switch is set to the **B** position.
- Do not use excessive force when changing the POWER SELECT switch.

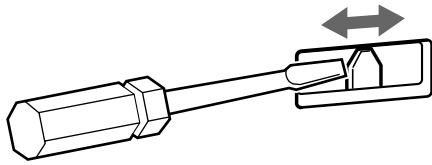

Reset button

When the installation and connections are over, be sure to press the reset button with a ball-point pen etc.

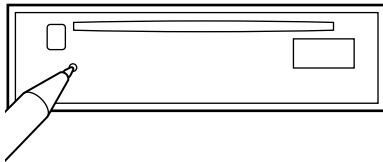

Connection diagram

Equipment used in illustrations (not supplied)

For connecting two or more changers, the source selector XA-C30 (optional) is necessary.

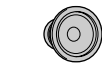

Front speakers



Rear speakers

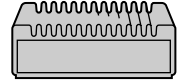

Power amplifier

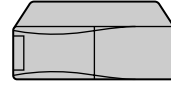

CD/MD changer

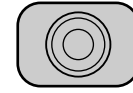

Active subwoofer

A

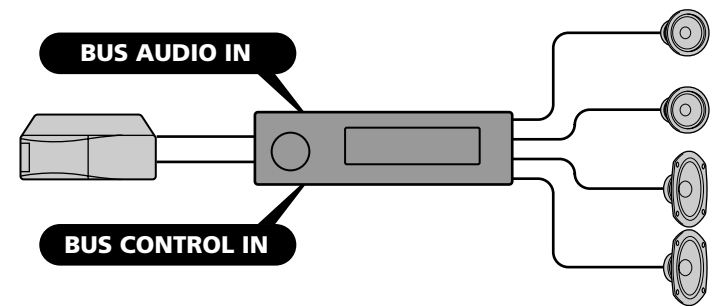

B

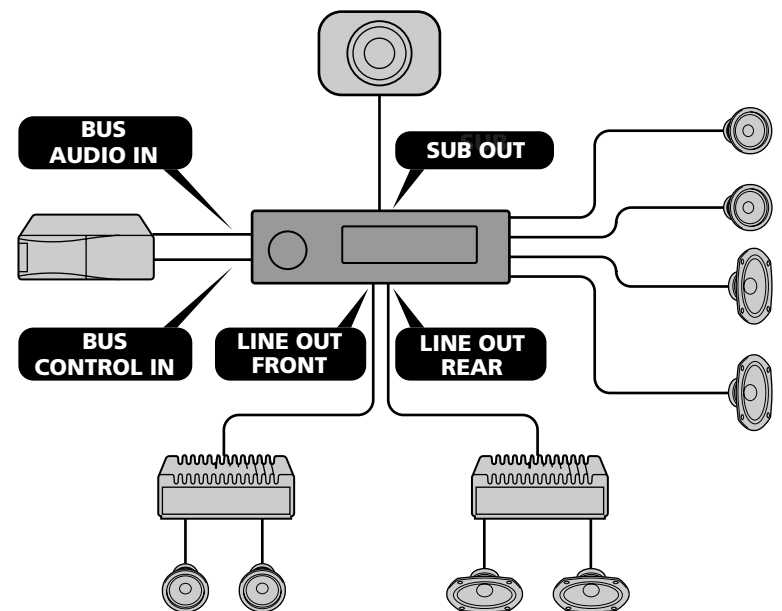

Inverter

- Install the inverter far away from the unit using double-sided adhesive tape or something similar.
- Be sure not to mount the inverter under a mat or in a place exposed to splashing water of air conditioner. It may cause electric shock or damage to the unit.

Note

If the inverter's cord is pinched, the display indications may not appear.

Connection example

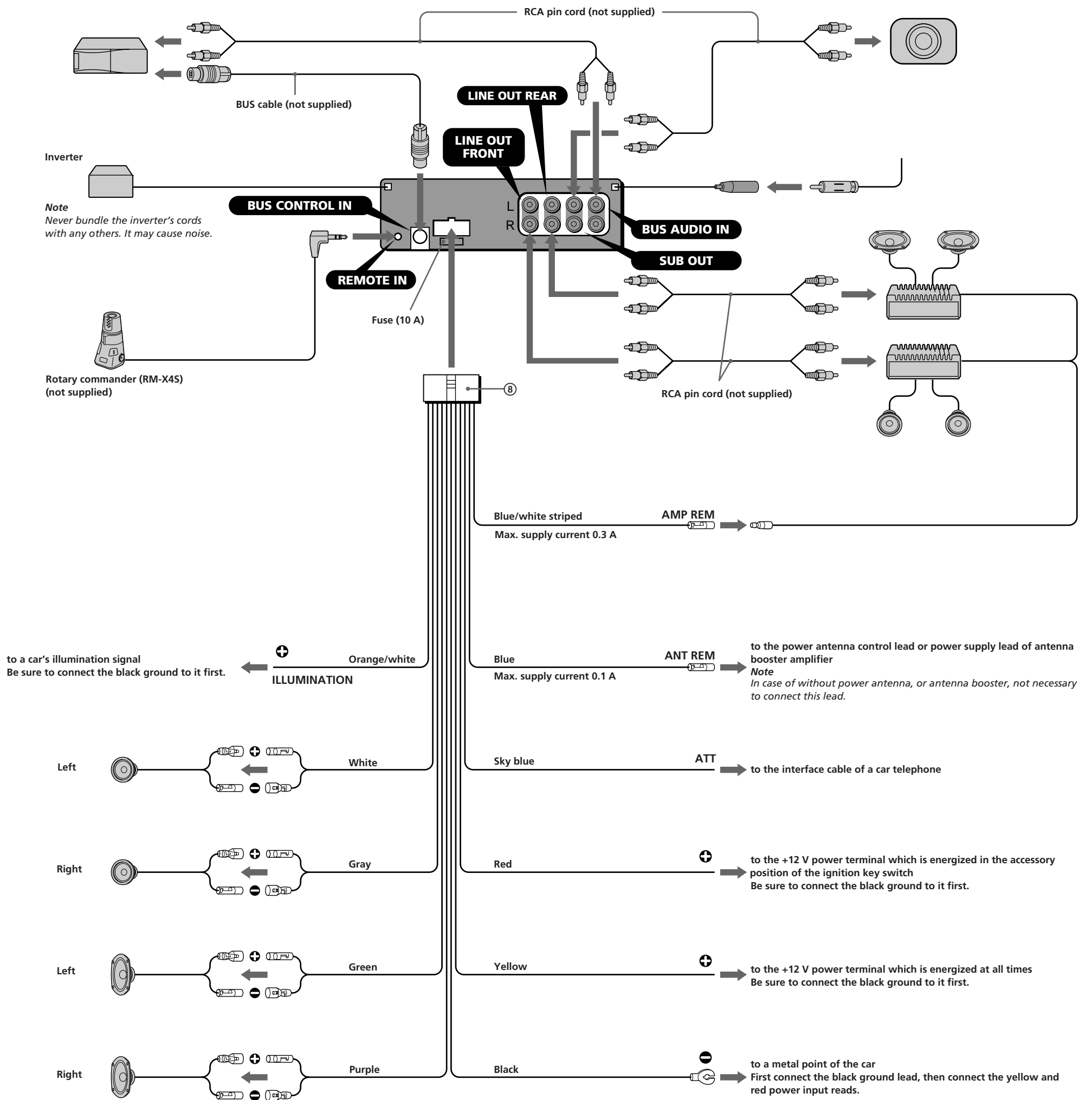

Notes on the control leads

- The power antenna control lead (blue) supplies +12 V DC when you turn on the tuner.
- A power antenna without relay box cannot be used with this unit.

Memory hold connection

When the yellow power input lead is connected, power will always be supplied to the memory circuit even when the ignition key is turned off.

Notes on speaker connection

- Before connecting the speakers, turn the unit off.
- Use speakers with an impedance of 4 to 8 ohms, and with adequate power handling capacities. Otherwise, the speakers may be damaged.
- Do not connect the terminals of the speaker system to the car chassis, and do not connect the terminals of the right speaker with those of the left speaker.
- Do not attempt to connect the speakers in parallel.
- Do not connect any active speakers (with built-in amplifiers) to the speaker terminals of the unit. Doing so may damage the active speakers. Therefore, be sure to connect passive speakers to these terminals.