

Micro Hi-Fi Component System



MDLP

CMT-M100MD

가

CAUTION : INVISIBLE LASER RADIATION WHEN OPEN AND INTERLOCKS DEFEATED. AVOID EXPOSURE TO BEAM.
ADVARSEL : USYNLIG LASERSTRÅLING VED ÅBNING NÅR SIKKERHEDSFRIBRYDERE ER UDE AF FUNKTION. UNDGÅ UDSÆTTELSE FOR STRÅLING.
VORSICHT : UNSICHTBARE LASERSTRÄHLUNG, WIENN ABDECKUNG GEÖFFNET UND SICHERHEITSVERRIEGELUNG ÜBERBRÜCKT, NICHT DEM STRAHL AUSSETZEN.
VARO! : AVATTAESSA-JÄ SUOJALUKITUS OHITETTAESSA OLET ALT-TIINA NÄKYMÄTTÖMÄLLÄ LASERSÄTEILYLE, ÄLÄ KATSO SÄTEESEEN.
VARNING : OSYNLIG LASERSTRÅLING NÄR DENNA DEL ÄR ÖPPRAD OCH SPÄRREN ÄR URKOPPLAD. BETRÄKTA EJ STRÄLEN.
ADVARSEL : USYNLIG LASERSTRÅLING NÄR DEKSEL ÅPNES OG SIKKERHEDSLÅS BRYTES, UNNGÅ EKSPONERING FOR STRÅLEN.
VIGYVAZÁRT! : A BUKKOLAT NYITÁSKOR LÁTHATÓAN LÉZERSUGÁRVESZÉLY! KERÜLJE A BESZÁRZÁST!

가



가

Dolby

Laboratories

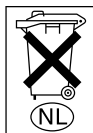

CLASS 1 LASER PRODUCT
 LUOKAN 1 LASERLAITE
 KLASS 1 LASERAPPARAT

(CLASS 1
 LASER)



..... 4
 5

..... 6
 R6 (AA)
 7
 8
 8

CD

CD 9
 CD 9
 — / /
 9

CD 11
 CD 12
 CD 13

MD -

MD 15
 MD 15
 MD 17
 MD 18
 MD 19

MD -	19
—	20
MD CD	22
— CD - MD	/	
CD - MD		
MD		
— TAPE - MD	24
MD		
—	25
6		
—	25
—	26
—	/ /	
	/ /	

MD -	30
MD		
—	30
—	32
—	33
—	34
—	35
—	/ /	
	/ A - B	
—	37
—	38
—	39
—	40
— S.F	41

	43
—	44
—	45
	(RDS)*	
	45
<hr/>		
-		
	46
	46
<hr/>		
-		
CD		
— CD - TAPE	46
MD		
— MD - TAPE	47
—	48
<hr/>		
	49
<hr/>		
—	49
—	50
	... 51	
<hr/>		
	53
<hr/>		
	54
MD	56
	57
	61
	63

()

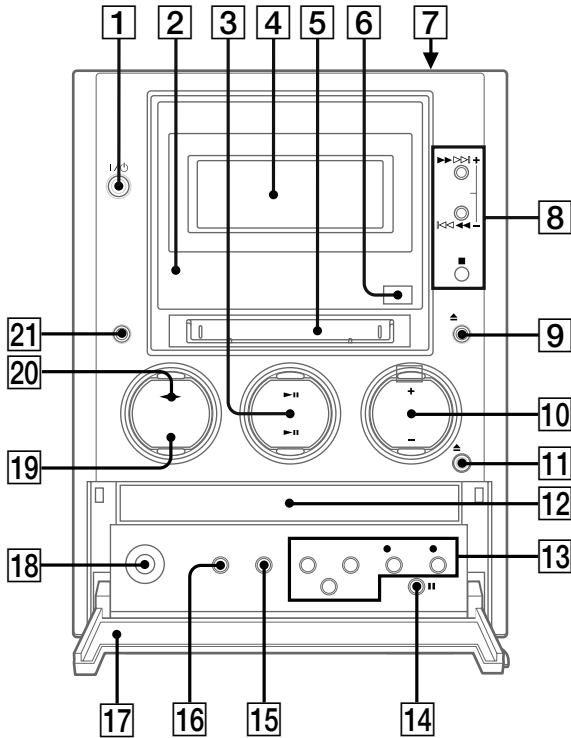

CD 12 (9)
 CD ▶|| 3 (9, 11)
 ENTER/START 13 (22, 24, 46, 47)
 FM MODE 15 (44)
 FUNCTION 21 (9, 11, 13, 15, 17, 18, 21, 25, 26, 31-39, 41, 46, 48, 53)
 GROUP 2 (18, 21, 22, 32-34)
 MD 5
 MD ▶|| 3 (15, 17, 18, 21, 25)
 PHONES 18

PLAY MODE/
 DIRECTION 16 (9, 11, 13, 15, 17, 24, 30, 46-48)
 REC MODE 13 (26)
 REPEAT 15 (10, 16)
 SYNCHRO MODE 13 (22, 24, 46, 47)
 TAPE ◀▶ 20 (46-48)
 TUNER BAND 19 (43, 44)
 TUNING MODE 16 (43, 44)
 TUNING +/- 8 (44)
 VOLUME +/- 10
17
4



I/O () 1 (8, 20, 30, 43, 44, 50, 52)
 ▲ PUSH OPEN/CLOSE 7 (46)
 ◀◀/▶▶ 8 (10, 16, 37, 39, 43, 44, 46)
 ◀◀/▶▶ 8 (10, 11, 13, 16-18, 26, 31, 33-38, 40, 41, 43)
 ■ 8 (10, 16, 21, 23-25, 29, 46-48)
 ▲ MD 9 (15, 16, 20, 30)
 ▲ CD 11 (9, 10)
 ● MD 13 (21, 25, 28, 40)
 ● TAPE 13 (48)
 || TAPE 14 (46, 48)

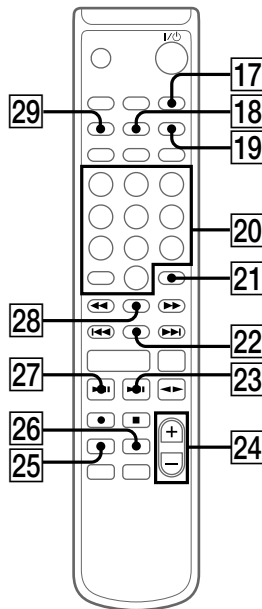
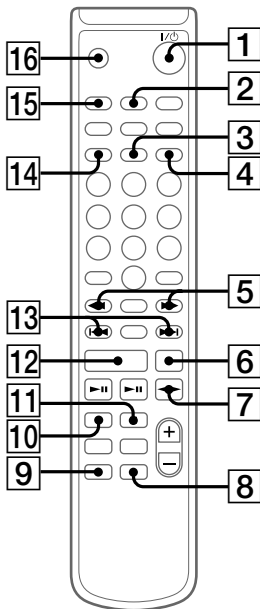

BASS/TRE **8** (49)

CD **▶▶** **23** (9, 11)

CLEAR **21** (11, 13, 17, 31, 45)

CLOCK/TIMER SELECT **15** (50, 52)

CLOCK/TIMER SET **2** (8, 50, 51)

CURSOR ←/→ **5** (8, 13, 31)

DISPLAY **22** (8, 11, 12, 17, 19, 21, 45)

DSG **9** (49)

ENTER/YES **4** (8, 11, 14, 17, 25, 26, 30, 33-35, 37, 38, 40, 41, 43, 45, 50, 51)

FM MODE **17** (44)

FUNCTION **12** (9, 11, 13, 15, 17, 18, 21, 25, 26, 31-39, 41, 46, 48, 53)

GROUP **29** (18, 20, 22, 32-34)

GROUP SKIP **18** (18, 22, 32, 34)

MD ● **10** (21, 25, 28)

MD **▶▶** **27** (15, 17, 18, 21, 25)

MENU/NO **14** (14, 26, 30, 32-35, 37-41, 43)

NAME EDIT/SELECT **3** (13, 30, 32, 45)

PLAY MODE **25** (9, 11, 13, 15, 17, 30)

REPEAT **26** (10, 16)

SCROLL **28** (14, 19, 32, 33)

SLEEP **16** (49)

TAPE **◀▶** **7** (46-48)

TUNER BAND **6** (43, 44)

TUNING MODE **19** (43, 44)

VOL +/- **24**

20 (10, 13, 16, 31, 44)

I/⏻ () **1** (8, 20, 30, 43, 44, 50, 52)

◀◀/▶▶ **5** (10, 16, 37, 39, 43, 44, 46)

■ **11** (10, 16, 21, 23-25, 29, 46-48)

◀◀/▶▶ **13** (8, 10, 11, 13, 16-18, 26, 31, 33-38, 40, 41, 43, 49-51)

-/+ **13** (44)

1

3

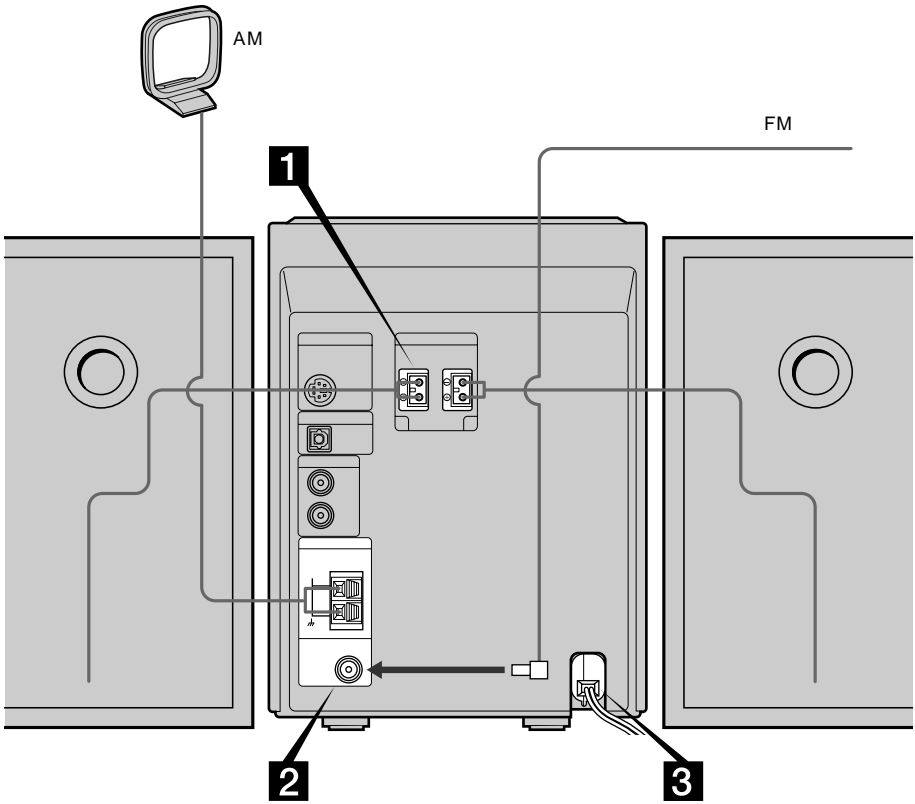

1

SPEAKER

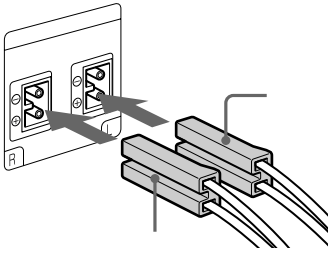

(AA) R6

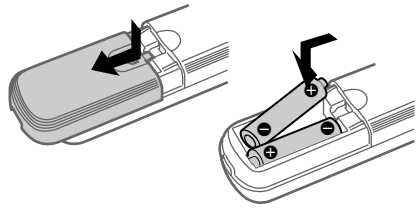

2 FM/AM
AM

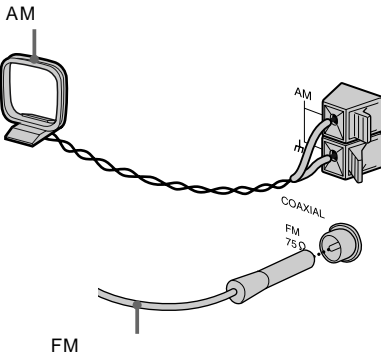
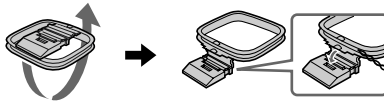

3

가





1 I/O

2 CLOCK/TIMER SET

5

3 "CLOCK SET" 가



가

4 ENTER/YES

가

가

DISPLAY

5 I◀▶

6 ENTER/YES

CURSOR→

가

DISPLAY

7 I◀▶

:

8 ENTER/YES

가

*

→

* →

2

DISPLAY

가

CD

1 ▲ CD

가

2

CD

CD (8 cm
CD)

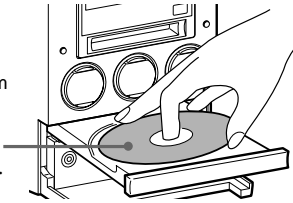

3 ▲ CD

▲ CD

CD가

CD

CD

FUNCTION

CD

CD

— / /

CD

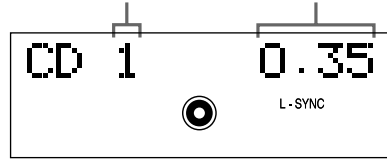

CD

1 FUNCTION
CD

2 가
PLAY MODE/DIRECTION (PLAY MODE)

	CD
SHUF	CD
PGM	CD
()	(11
	” CD
)

3 CD ▶▶

CD ()

10

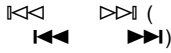
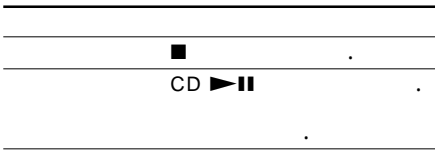

```

( ) "REP"
      "REP1"
      REPEAT
      REP: CD

      REP1:
      "REP" "REP1"

      REPEAT
  
```

CD ▲ CD

1 >10

2

0

10/0

:

3 10/0³⁰

>10







CD

25

1 FUNCTION
CD

2 "PGM"
PLAY MODE/DIRECTION (
PLAY MODE)

3  (가   

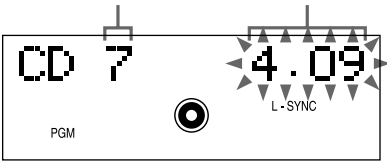

4 ENTER/YES

"Step"
가

CLEAR

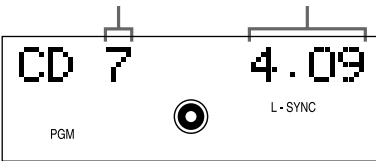

5

3 4

6 CD 

 ( ) 

DISPLAY

"PGM"
"SHUF" 가
PLAY MODE/
DIRECTION (
PLAY MODE)

3 4

가

CLEAR

3 5

10

CD

CD ()

•
 • CD 가21 "-----"가
 , CD 100 CD
 CD ▶▶

CD

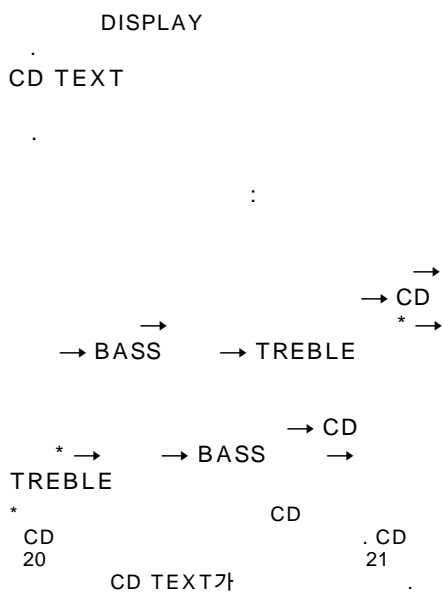

CD

50 CD 20
 CD
 "TEXT"가 CD
 CD
 ()

1 FUNCTION
 CD
 "SHUF" "PGM"
 PLAY
 MODE/DIRECTION (PLAY MODE)

2 SELECT NAME EDIT/
 가

3 NAME EDIT/SELECT

:
 Selected AB* () →
 Selected ab* () →
 Selected 12 ()
 *

'-/,.:!?'
 가
 ▷▷ (◀◀ ◀◀
 가

& + < > _ = " ; # \$ % @ * `

4
 1 가
 ▷▷ (◀◀
 ◀◀

2 CURSOR→
 가 가
 가 가

1 NAME EDIT/SELECT

2 10/0 가

5 3 4

1 가
 ←CURSOR
 CURSOR→

2 CLEAR
 3 4

CD

CD ()

6 ENTER/YES
가

MENU/NO

1 FUNCTION
CD

2 MENU/NO

3 "Name Check?" 가
◀◀ ▶▶ (▶▶)
ENTER/YES

4 ▶▶ (▶▶) 01 50

SCROLL

1 FUNCTION
CD

2 MENU/NO

3 "Name Erase?" 가
◀◀ ▶▶ (▶▶)
ENTER/YES

4 ▶▶ (▶▶)

"No Name"
5 ENTER/YES

"Complete!" 가

3
"All Erase?" 가
▶▶ (▶▶)

ENTER/YES

2 4 MENU/
NO

MD

MD

가

가
가

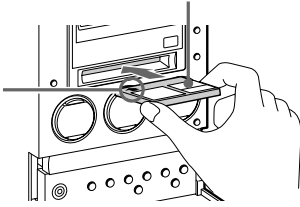

MD

MD

MD

MD가
▲ MD

MD

— / /

MD

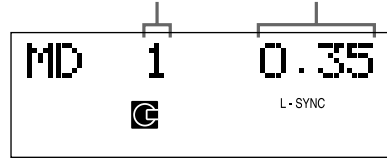

MD -

1 FUNCTION
MD

2 가
PLAY MODE/DIRECTION (PLAY MODE)

()	MD
SHUF ()	MD
PGM ()	MD (17 " MD)

3 MD ▶||

MD ()

10

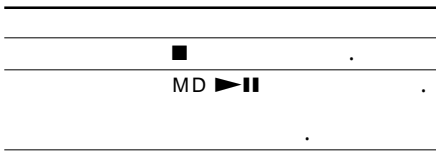

1 >10 .
 2 .
 0 10/0 .
 :
 3 10/0 30 >10 .

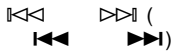

“ REP ”
 () “ REP1 ”
 REPEAT
 REP: MD
 REP:
 “ REP ” “ REP1 ”
 REPEAT

MD ▲ MD



MD

25

1 FUNCTION
MD

2 "PGM"
PLAY MODE/DIRECTION (
PLAY MODE)

3 가
▶▶ (◀◀ ▶▶)

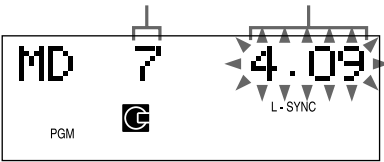

4 ENTER/YES

"Step" 가

CLEAR

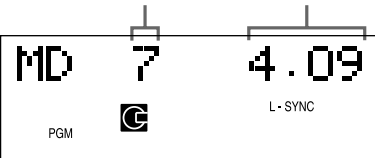

5

3 4

6 MD ▶▶

▶▶ (◀◀ ▶▶)

DISPLAY

"PGM"
"SHUF" 가
PLAY MODE/
DIRECTION (
PLAY MODE)

3 4

가

CLEAR

3 5

16

MD -

MD ()



GROUP
• MD
"-----" 가
1,000
MD ▶▶

20

1 FUNCTION
MD

2 GROUP
GROUP

3 GROUP SKIP

5

4 ((()

5 MD ▶▶

MD 가

" MD " (15) " MD
" (17)

MD

MD

DISPLAY

→ MD → *1 → →
 *2 → → BASS →
 TREBLE

가 (가 MD *3 →) → MD
 *4 → → BASS →
 TREBLE

*1

*2

*3

) ()
 MD "-----" 가 1,000

*4

MD

SCROLL

SCROLL

SCROLL

30

" MD

32

MD -

MD ()

MD

가

CD

- MD 가 *1

CD

• DIGITAL OPTICAL IN

- MD 가 *1

가

ANALOG IN

- MD 가 *2

(27

) 가

*1 " MD " 56

*2 " MD

MD

MD

()

MD
MD (),

TOC TOC*3 .

*3 TOC:

▲ MD MD I/O ()
" TOC " " STANDBY " 가
. TOC가

MD MD (TOC)가
. TOC MD
I/O

TOC
TOC가 (" TOC ")
" STANDBY " 가

MD
MD
MD . MD
MD

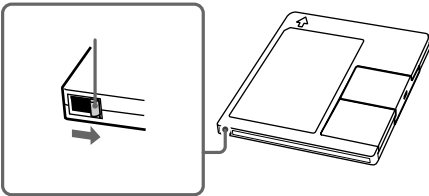

—
?
MD
MDLP MD
CD

GROUP

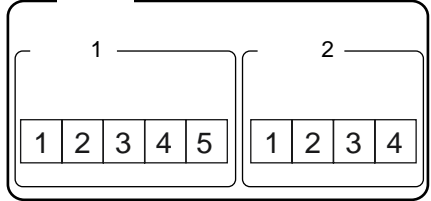
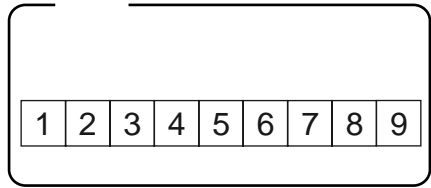

-) (18
-) (32)
- (33)
- (34)

MD

가?

가

MD

0 ; Favourites // 1 - 5 ; Rock // 6 - 9 ; Pops // ...
 ┌──────────┬──────────┬──────────┐
 ① ② ③

- ① " Favourites "
- ② 1 5 " Rock "
- ③ 6 9 " Pops "

MD

가

MD

* GROUP

35 " MD

MD

MD

가

GROUP

CD

1 가 MD

2 FUNCTION

3 GROUP
GROUP

4 ● MD (MD ●)

" New Group " MD

가

5 MD ►||

MD

가

2 5

4 ● MD (MD ●)

" Group Full! "

가

((32))

DISPLAY
가

MD

가
MD 99

가 " Group Full! "

MD

()

MD CD

가 .

— CD-MD

1 21 “ ”
1 3

1 가 MD
2 CD

2 ● MD (MD ●)
“New Track ” MD
가 .

4
3
GROUP
GROUP

3
GROUP SKIP

4 “CD-MD SYNC ” 가
SYNCHRO MODE

4 MD ►||

5 ENTER/START
“ Press START ” 가
MD CD

2 ● MD (MD ●)
“ Group Full! ”

가
()
(32) .

7
6

. 가 .
.

. 가
“ Group Full! ”
가 .

7
GROUP SKIP

7 “Press START” 가
ENTER/START

CD MD 가

■
•
•
5 “CD”
•
CD TEXT
(MD
)
30 “MD
”
“TEXT” 가

MD MD가 CD
가
MD CD

1 가 MD

2 CD
3 “DUAL SYNC” 가
SYNCHRO MODE

4 46 “CD
” 4 6

MD

MD CD
— CD-MD

CD-MD
MD CD

“MD CD” 4
“HISPEED SYNC” 가
SYNCHRO MODE

5 “x2” 가

5 ENTER/START
“Retry” 가
가

• 가
CD-MD

• CD 가

CD-MD
MD 가 “x1” 가 CD-
MD

MD

MD CD ()

- CD-MD
- 가
- ” 4 “MD CD
- CD-MD

—
—

MD

— TAPE-MD

MD

TYPE I ()

1 가 MD

2

3 “TAPE-MD SYNC” 가
SYNCHRO MODE

4 ENTER/START
“Press START” 가
MD

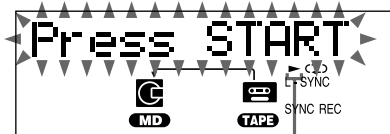

▶가
◀가

3 4

5

↔가
↔ (↔)
가 PLAY MODE/
DIRECTION

6 “Press START” 가
ENTER/START

가 MD

■

MD가
MD 가

MD

—

CD

1 가 MD

2 FUNCTION

3 ● MD (MD ●)

MD 가

4 MD ►||

■

DISPLAY 가 MD

6

FM

가

가

6

:

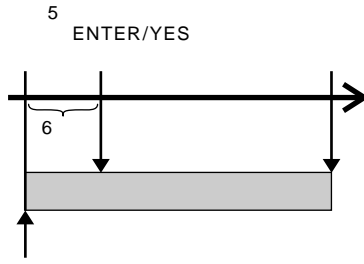

1 가 MD

2 FUNCTION

3 ● MD (MD ●)

MD 가

4

5 ENTER/YES

■

3 가 MD 가

ENTER/YES 6 6 가

MD



— / / /

가 :LP2 LP4 (MDLP) .
LP2 가

LP4 가

가
가

LP4 (4x)

가

LP2 (2x)

1) REC MODE (CD-MD

STEREO REC () → LP2
REC (LP2) → LP4 REC
(LP4) → MONO REC ()

2 MENU/NO

• MDLP (LP2 LP4)
MD MDLP

• MODE 가 REC

• REC MODE MONO

• MDLP MD S.F

MDLP
“ LP: ” 가

MDLP

“ LP: ” 가

“ On ”

1 FUNCTION
MD

2 MENU/NO

3 “ Setup? ”
▷▷ (◀◀ ▶▶)
ENTER/
YES

4 “ LP Stamp On ” “ LP Stamp
Off ” 가 ◀◀ ▶▶ (◀◀ ▶▶)
ENTER/YES

5 ◀◀ ▶▶ (◀◀ ▶▶)
ENTER/YES

“ LP: ” 가	LP Stamp On ()
“ LP: ” 가	LP Stamp Off

6 MENU/NO

- “LP:” MDLP
 . MDLP
- “On” “LP:”가
 MD
 가
 “LP:”가
 “LP:”가
- CD
 DIGITAL OPTICAL IN
 가
 ANALOG IN
-
-
- (38
 “) .
 ”
-
- 가
 가
 가 2
 가

1 FUNCTION
 MD

2 MENU/NO

3 “Setup?”
 ▷▷ (◀◀ ◀◀)
 ENTER/
 YES

4 “ T.Mark Off ” “ T.Mark
 LSync ” 가 ◀◀ ◀◀)
 (◀◀ ◀◀)
 ENTER/YES

5 ◀◀ ◀◀ (◀◀ ◀◀)
 ▶▶)
 ENTER/YES

T.Mark LSync
 ()

T.Mark Off

가 “L-SYNC”

6 MENU/NO

MD

()

3

CD

1 "Setup?" MENU/NO
ENTER/YES

2 "LS(T)" 가
▶▶ (◀◀ ◀◀ ▶▶)
YES ENTER/

3 ◀◀ ▶▶ (◀◀ ▶▶)
ENTER/YES
-72 dB 0 dB
2 dB -50 dB

4 MENU/NO

3

● MD (가 MD ●)

가

CD

가

3
3 (30)
가 3 MD

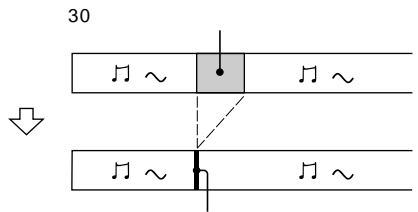

30

3

30 MD 가

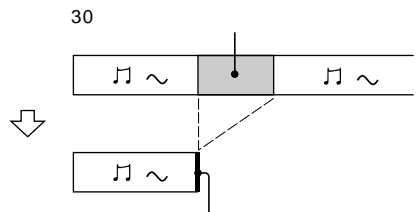

30

3

1 FUNCTION
MD

2 MENU/NO

3 "Setup?"
▷◁ (◀▶)
ENTER/

YES

4 "S.Space Off" "S.Space On"
◀▶ (◀▶)
ENTER/YES

5 ◀▶ (◀▶)
ENTER/YES

S.Space On

()

S.Space Off

6 MENU/NO

"Auto Cut"
MD ▶▶

MD

CD

1

2 ● MD (MD ●)

MD 가

3 MENU/NO
"Setup?"
ENTER/YES

4 "Level Adjust?" 가

◀▶ (▶▶)

ENTER/YES

5 ◀▶ (▶▶)

가
"OVER" 가

6 ENTER/YES

7 MENU/NO

8 ■ MD 가

• CD - MD

MD

MD

:

- 가 MD
- MD 가

1 MD

MD 가
MD

2 “SHUF” “PGM”
PLAY

MODE/DIRECTION (
PLAY MODE)

MD

MD (40)
MD

MENU/NO

▲ MD MD I/⏻ ()
“TOC” “STANDBY” 가
TOC가

MD MD (TOC)가
TOC MD

I/⏻

TOC
TOC가 (“TOC”)
“STANDBY” 가

MD

“TEXT” 가
CD TEXT MD

:

- “TEXT” 가 CD
- TEXT 가
- “TEXT” 가
NAME EDIT/SELECT
ENTER/YES

CD TEXT 가

- CD MD
CD TEXT 가

MD 1,700

32 “

MD

20

1 FUNCTION
MD

2

가

▶▶▶ (◀◀◀

▶▶▶) ◀◀◀

NAME EDIT/SELECT

MD

()가

NAME EDIT/SELECT

3

NAME EDIT/SELECT

:

Selected AB* () →

Selected ab* () →

Selected 12 ()

*

1

^_/,.(!?)

가

▶▶▶ (◀◀◀

▶▶▶) ◀◀◀

가

&+<>_=";#\$\$%*`

4

1

가

▶▶▶ (◀◀◀

▶▶▶) ◀◀◀

2 CURSOR→

2

CURSOR→

가

가

가

가

가

MD

1

NAME EDIT/SELECT

2

10/0

가

5

3

4

1

가

←CURSOR

CURSOR→

2

CLEAR

3

4

6

ENTER/YES

가

MD ()



• "abc//def"
"//"

SCROLL

SCROLL

SCROLL

1 FUNCTION
MD

2 MENU/NO

3 "Nm Erase?" 가
▷◁ (

◀◀ ▶▶
ENTER/

YES

4 ◀◀ ▷◁ (▶▶
▶▶)
ENTER/YES
"Complete!" 가

MD 1,700

1 FUNCTION
MD

2 GROUP
GROUP

3 GROUP SKIP

4 가 NAME
EDIT/SELECT
가

5 30 " MD
3 6 "

"abc//def"
"//"

1 GROUP
GROUP

2 GROUP SKIP
SCROLL

SCROLL

1 FUNCTION
MD

2 GROUP
GROUP

3 MENU/NO

4 "Nm Erase?" 가
▶▶ (◀◀
ENTER/)

YES

5 가
GROUP SKIP
ENTER/YES

"Complete!" 가

1 FUNCTION
MD

2 GROUP
GROUP

3 MENU/NO "Edit
Menu" 가

4 "Gp Create?" 가 ◀◀
▶▶ (◀◀ ENTER/)

YES

5 30 "MD
3 6 "

6 ◀◀ ◀◀ ▶▶ (가
▶▶) ENTER/YES

7 ◀◀ ◀◀ ▶▶ (가
▶▶) ENTER/YES

(ENTER/YES
)

"Complete!" 가

MD

()

- 6 "None"
 ◀▶ (▶▶)
 ▶▶)
 ENTER/YES
 "Complete!" 가
-
- MD
 5 "Assign None"
-
- 5 "Group ** ()" 가



—
 가
 , MD

—
 . (.)

- 1 FUNCTION
 MD
- 2 GROUP
 GROUP
- 3 GROUP SKIP
- 4 MENU/NO "Edit
 Menu" 가
- 5 "Gp Release?"
 ▶▶ (◀▶)
 ENTER/YES
 "REL Gp** ()??" 가
- 6 ENTER/YES
 "Complete!" 가

MD

—

MD

1 FUNCTION
MD

2 GROUP
GROUP

3 MENU/NO “ Edit
Menu ” 가

4 “ Gp All REL? ” 가
▷▷ (◀◀ ▶▶)

ENTER/YES
“ All REL?? ” 가

5 ENTER/YES

“ Complete! ” 가



—

MD

가 가

- ()
- ()
- (A - B)

—

MD 가

가

:2

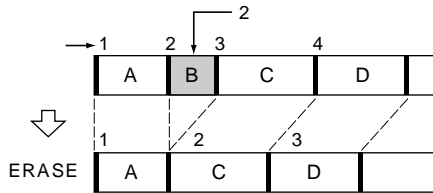

1 FUNCTION
MD

2 MENU/NO “ Edit
Menu ” 가

3 “ Tr Erase? ” 가
▷▷ (◀◀ ▶▶)
ENTER/

YES

MD

()

4 가 ()

5 ENTER/YES

“ Complete! ” 가

Protect ” 가 “ Tr “ Tr Protect ” 가

—

1 FUNCTION MD

2 MENU/NO “ Edit Menu ” 가

3 “ All Erase? ” 가 ENTER/YES

4 ENTER/YES

“ Complete! ” 가

MD

— A - B

* 1 1/86

:2

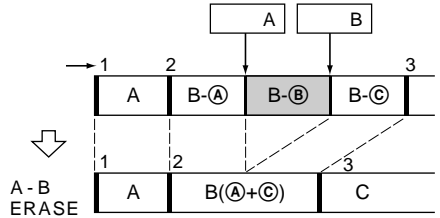

1 FUNCTION MD

2 MENU/NO “ Edit Menu ” 가

3 “ A - B Erase? ” 가 ENTER/YES

4 가 ENTER/YES 가 A

“ —Rehearsal— ” “ Point A ok? ” 가

5 ⏪⏪ ⏩⏩ ()
 (A) 1/86 (1) *
 .

⏪⏪ ⏩⏩
 (⏪⏪ ⏩⏩)
 .
 * 2 ()
 LP2 (LP4) 4

6 A 가
 5

7 A 가
 ENTER/YES
 " Point B set "
 .
 (B)

8 가 B
 ENTER/YES
 .
 " A - B Ers " " Point B ok? " 가
 가 A
 B

9 ⏪⏪ ⏩⏩ () ⏪⏪
 ⏩⏩ B
 .
 5

10 B 가
 ENTER/YES
 " Complete! " 가
 .

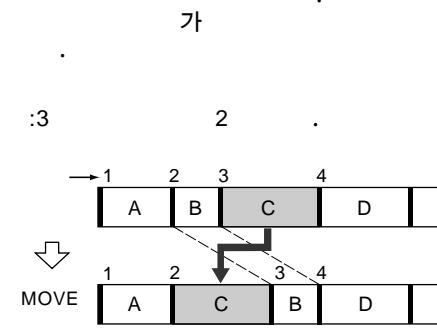

- 1 FUNCTION
MD
- 2 MENU/NO " Edit
Menu " 가
- 3 " Move? " 가 ⏪⏪ ⏩⏩
⏩⏩ () ENTER/
YES
- 4 가 ⏪⏪ ⏩⏩ () ⏪⏪
⏩⏩ ENTER/YES



MD

()

5 >>> (가 <<< <<< >>>)

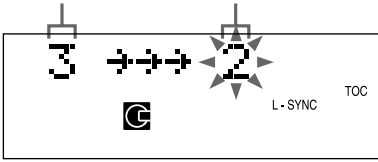

6 ENTER/YES

“Complete!” 가



—

:2

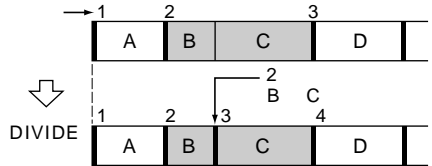

1 FUNCTION MD

2 MENU/NO “ Edit Menu ” 가

3 “ Divide? ” 가 <<< >>> (<<< >>>) ENTER/YES

4 <<< >>> (>>>) ENTER/YES “—Rehearsal—” <<<

5 ⏪ ⏩ () *
 1/86 (1) *

⏪ ⏩
 (⏪ ⏩)
 * LP2 2 () 4
 (LP4)

6 가
 ENTER/YES
 “Complete!” 가
 ” (30) “ MD

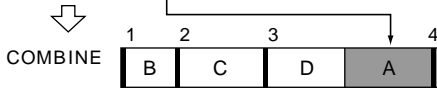
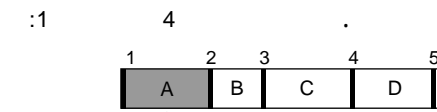
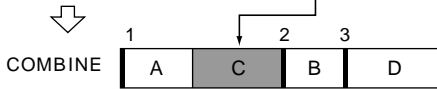
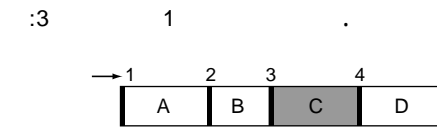
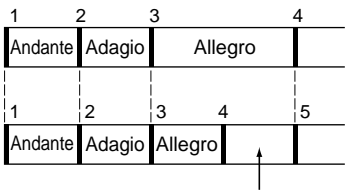

MD

- 1 FUNCTION
MD
- 2 MENU/NO “ Edit
Menu ” 가

()

3 "Combine?"
▶▶ (◀◀ ◀◀)
ENTER/

YES

4 가 ◀◀ ◀◀ (▶▶)
ENTER/YES

1 4 .

5 가 ◀◀ ◀◀ (▶▶)

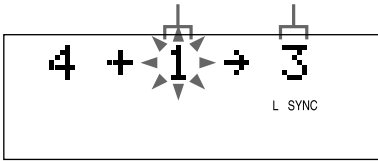

6 ENTER/YES

"Complete!" 가

MONO) (, LP2, LP4



— MD

• MD (MD ●)
ENTER/START

• TOC MD

S.F
1 MENU/NO

2 "Undo?" 가 ◀◀ ◀◀ (▶▶)

3 ENTER/YES

4 ENTER/YES

"Complete!" 가



— S.F

S.F ()

가

가

1 FUNCTION
MD

2 MENU/NO "Edit
Menu" 가

3 "S.F Edit?" 가
▷▷ (◀◀ ▶▶)
ENTER/
YES

4 "Tr Level?" 가
▷▷ (◀◀ ▶▶)
ENTER/
YES

5 ◀◀ ▶▶ ()
ENTER/YES 가

"Level 0dB" 가

6 ◀◀ ▶▶ ()
-12 dB +12 dB
2 dB
.가
"OVER" 가

7 ENTER/YES
"S.F Edit OK?" 가

8 ENTER/YES
가
"S.F Edit: ** %" 가

"Complete!" 가

3 7 MENU/
NO .8

1 FUNCTION
MD

2 MENU/NO "Edit
Menu" 가

3 "S.F Edit?" 가
▷▷ (◀◀ ▶▶)
ENTER/
YES

MD

()

4 "Fade In?" "Fade Out?"
⏪ ⏩ ()
ENTER/YES

5 가
⏪ ⏩ ()
ENTER/YES

"Time 5.0s" 가

6 ⏪ ⏩ ()

. 1.0 15.0
0.1

7 ENTER/YES

"S.F Edit OK?" 가

8 ENTER/YES

가

"S.F Edit: ** %" 가

"Complete!" 가

3 7 MENU/
NO . 8

.
가
MD MD 가
가
S.F



20 FM 10 AM

1

2 TUNER BAND "FM"
"AM"

3 "AUTO" 가 TUNING
MODE

4
가
"TUNED" "STEREO" (
)가

5 MENU/NO

6 "Memory?" 가
 (
 YES ENTER/

가

1

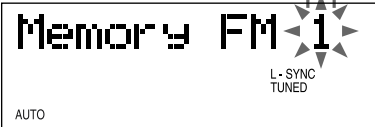

7 ENTER/YES

"Complete!" 가

8 2 7

TUNING MODE

가
3 "AUTO" "PRESET"
TUNING

MODE

2

AM

)

AM

(

. AM
AM

10 kHz)

9 kHz

.

AM

AM



—

(43 ") .

1 TUNER BAND " FM " " AM "

2 " PRESET " 가 TUNING MODE

3 TUNING + - (+) (* RDS **)

* (") .

**

I/⏻

3 10

1 >10

2 0 10/0

: 2 10/0 20 >10

- 2 " AUTO " " PRESET " TUNING MODE ▶▶ ◀◀

) .

- 2 " AUTO " TUNING MODE ◀◀ ▶▶ 가 가 () .

TUNING MODE .

- FM FM MODE " MONO " 가

(RDS)

()

?

(RDS)*

가

1

12
() .

(44 ") .

2 13

" CD "

2 6

가 RDS RDS

* FM RDS

. RDS

DISPLAY

RDS

FM
RDS

1

2 NAME EDIT/SELECT

RDS

3 CLEAR

DISPLAY

4 ENTER/YES

* → → → BASS
→ TREBLE
* RDS

1 ▲ PUSH OPEN/CLOSE

2

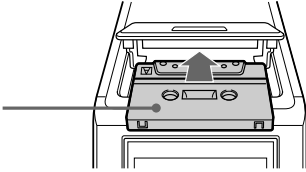

TYPE I ()

1 FUNCTION
TAPE

2

(↔)*가
DIRECTION

3 TAPE ◀▶

↔가
↔ ()
PLAY MODE/

TAPE ◀▶

* 가

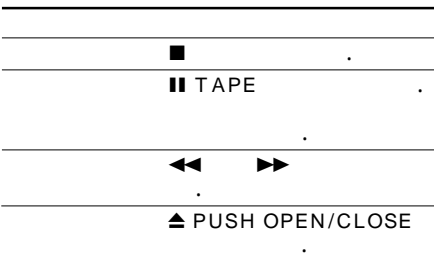

CD

— CD-TAPE

TYPE I ()

1 가

2 CD

3 “CD-TAPE SYNC” 가
SYNCHRO MODE

4 ENTER/START
“ Press START ” 가

CD

TAPE ◀▶

5

(↔)가
DIRECTION

↔가
↔ ()
PLAY MODE/

6 “ Press START ” 가
ENTER/START

CD

가



MD

— MD-TAPE

TYPE I ()

- 1 가
- 2 MD
- 3 “MD-TAPE SYNC” 가
SYNCHRO MODE

- 4 ENTER/START
“ Press START ” 가

MD

- 5
↔ 가
↔ ()
DIRECTION PLAY MODE/
6 “ Press START ” 가
ENTER/START

TAPE ◀▶

PLAY MODE/

MD

가

MD

()



—

CD MD

TYPE I ()

1 가
2 FUNCTION

3 ● TAPE 가

4
(↔)가
DIRECTION

5 || TAPE

TAPE ◀▶

↔가
↔ ()
PLAY MODE/



•

•

)
DSG
DSG DSG

1 BASS/TRE
BASS TREBLE
2 "BASS" "TREBLE"
◀◀ ▶▶

7

—
SLEEP

)
:
SLEEP OFF → AUTO* → 90min →
80min → ... → 10min

* CD, MD
(100)

TUNER 100

SLEEP

SLEEP

"SLEEP OFF" 가
SLEEP

MD
"AUTO"



—

1 (8) “) .

• CD: CD

“ CD (11) ”) .

• MD: MD

“ MD (17) ”) .

• :
• :

“ ” (44)) .

2 VOLUME + - (VOL + -)

3 CLOCK/TIMER SET “ DAILY SET ”

4 ENTER/YES

“ ON ” 가

5



ENTER/YES

가



ENTER/YES

6 5

7



8

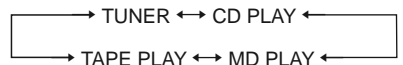

ENTER/YES

9 I/O

/ 1 CLOCK/ TIMER SELECT

2 “ DAILY SELECT ” 가

◀◀

▶▶

ENTER/YES

1

1 CLOCK/ TIMER SELECT

2 “ TIMER OFF? ” 가

◀◀ ▶▶

ENTER/YES

-
-
- 가
- (30)
- ANALOG IN



(43 “) (8) .

1 (44 “ ”) .

2 CLOCK/TIMER SET
“ DAILY SET ”

3 ⏪ ⏩
“ MD REC SET ” “ TAPE
REC SET ”
ENTER/YES
“ ON ” 가

4 ⏪ ⏩
ENTER/YES
가
⏪ ⏩

5 4
ENTER/YES

6 MD ⏪ ⏩ ()
LP2)
ENTER/YES



()

7 가 MD

MD

가

(30)

MD

15

30

8 I/O

MD

/ 1 CLOCK/
TIMER SELECT

2 " MD REC? "
" TAPE REC? "

◀◀ ▶▶

ENTER/YES

1

1 CLOCK/
TIMER SELECT

2 " TIMER OFF? " 가

◀◀ ▶▶

ENTER/YES

(45

"

MD),

PC LINK

PC LINK

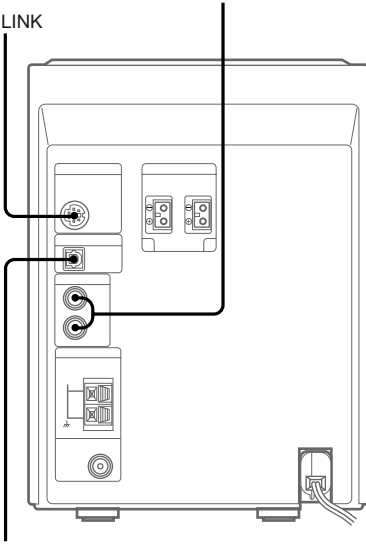

*

*

FUNCTION
OPTICAL IN

FUNCTION
ANALOG IN

PC (Sony)

PC LINK



가 AC ()

가

• AC ()

— 가
— 가
—
—

(,)

가

가

가 가

가
MD
가 MD
CD
가
CD

가 Sony

TV
가 15 30 TV
TV
TV 가

MD
MD
가

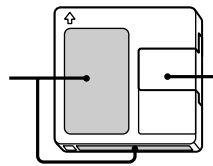

• MD

• 가 CD MD
 :
 — CD
 — CD (
) 가
 — CD
 — CD
 — CD
 — CD
 • CD
 가
 :
 — CD
 가
 —
 — 가
 • 가
 (35 “ ”
).
 CD
 • CD CD
 • CD CD 가
 CD
 • CD
 • CD
 • (, , ,)

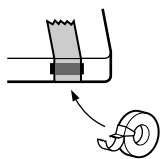
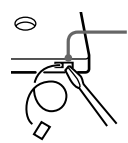

CD-R/CD-RW
 CD-R/CD-RW

10
 20 30

MD

MD 가 . MD 2 *

MD 가 " Disc * LP2 :

MD 255 " Disc Full! " 4 LP4 : 8 가

MD 255 " Disc Full! " 가 MD 가

(255) " Disc 가 . 가

" Disc Full! " 가 " L-SYNC " (27)가

" Group Full! " 가 : 1-

" Group Full! " 가 가 2

가 가

" Group Full! " 가 * LP2 : 8

(LP4 LP2 : 8

12 * CD

* LP2 :

24 LP4 : 48

CD, MD, DAT



가

가

가

*
1 CD MD)

(

가 Sony

2 ()



• VOLUME + - ()
VOL + -)

*
MD CD

- (7
-)
- CD-MD



가

• (7)



-
-
- ()



“ 0:00 ” ()
“ 12:00 AM ” ()
• (8
).)



• (8
).)



()

가
 • CLOCK/TIMER SELECT
 “DAILY” “REC”가
 (50 52)
 • (50 52)
 • (49)
)

• 가 가 가
 • (R6/AA)
 •

CD
 CD 가
 • CD
 • ▲ CD
 CD

CD가
 • 가 Sony

• CD CD가
 • CD (55)
 • CD
 • CD
 • CD
 • CD 가
 • CD ▶▶

가
 • CD (55)
)
 • CD
 • (,
) 가 가
 • 가 가
 •

• “PGM” “SHUF”가
 PLAY MODE/DIRECTION
 PLAY MODE)
 (

“OVER”가
 • CD ◀◀ ◀◀

MD
 MD가 가
 • 가 MD 가
 가 MD

• MD
 • “TOC” “STANDBY”가

• MD
 • MD 가
 • MD ▶▶
 • GROUP GROUP

가
 • MD
 • (가 가
 • 가 가
 • 10
 20

• “PGM” “SHUF” 가
 PLAY MODE/DIRECTION
 (PLAY MODE)

“OVER” 가
 • MD
 • <<<<

“OVER” 가
 • (29)

TOC가
 • MD MD
 30 MD (20)

• MD (20)
 • (53)
 • 가 MD
 (35)

MD ()
 • (41)

가
 • 가
 • (55)
 • 가

가
 • 가
 • / 가 (55)

가
 • / 가 (55)

(55)

가
 • / 가 (55)

• 57 “ ”
 • (53):
 가
 • 가

가 (29)

()

.
 . (43) .
 . (7
 .) .
 .
 가
 . FM
 . 가
 . AM 가 가 Sony
 .
 FM
 . "STEREO" 가
 FM MODE
 . " /
 ."
 .
 MD
 .
 .
 .

- 1
- 2
- 3 I/⏻
- 4 ■, ENTER/START I/⏻

CD



가

가 Sony

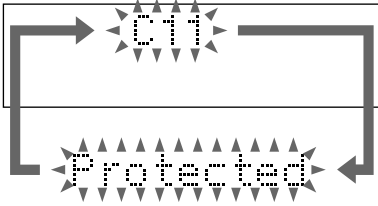

C11/Protected

MD가
→MD
(20) .

C12/Cannot Copy

CD-ROM
CD MD
→
가

C13/REC Error

→
MD가
→MD

C13/Read Error

MD 가
→ MD 가

C14/Toc Error

MD 가
→MD
→ MD (36)
) .

C41/Cannot Copy

→
(57) .

가
가

MD

Assign None

MD

Auto Cut

MD 가 30

Blank Disc

가 MD가 MD

Cannot Edit

• MD가
•

Cannot REC

• MD가
• MD

Cannot SYNC!

• MD 가
• MD가
• MD 가

()

Complete!
MD

Disc Full!
MD 가

Eject
MD 가 MD

Group Full!
가

Impossible
• 가
• MD
•

Incomplete!
가 가

Initialize

Name Full

No Change

ENTER/YES

No Disc
MD 가

OVER
MD ▶▶

Step Full!
26 ()

Push STOP!
PLAY MODE/DIRECTION (PLAY MODE)

—Rehearsal—
A - B MD가

S.F Edit!
S.F ()

S.F Edit NOW
S.F () I/⏻

Smart Space
3 30
가

Text Protect
MD CD TEXT

TOC Reading
MD 가 MD TOC

TOC Writing
MD 가

Track End

Tr Protect

CD

Cannot Edit
CD TEXT

CD No Disc
CD가

Complete!
CD

Name Full
50

OVER
CD ▶▶

Step Full!
26 ()

Cannot SYNC!
가

No Tab

No Tape
가

(HCD-M10)

DIN (): 10 + 10
(1 kHz 6 ,
DIN)

RMS (): 15 + 15
(1 kHz 6 ,
10% THD)
(): 25 + 25

DIN (): 10 + 10
(1 kHz 6 ,
DIN)

RMS (): 15 + 15
(1 kHz 6 ,
10% THD)

ANALOG IN (): 250 mV,
47

DIGITAL OPTICAL IN (: 32 kHz, 44.1 kHz 48 kHz)

PHONES (): 16

SPEAKER: 6
16

CD

(λ=780 nm)

:
2 Hz - 20 kHz
(±0.5 dB)

()

(SS-CM100)

2

MD

(λ=780 nm)

44.1 kHz
5 Hz - 20 kHz
(±0.5 dB)

4 2
Sony TYPE I
50 - 13,000 Hz
(±3 dB)
±0.15% W. Peak
(IEC)
0.1% W. RMS (NAB)
±0.2% W. Peak
(DIN)

10 cm,
2.5 cm,
6

230 V AC, 50/60 Hz
220 V AC, 60 Hz

55

0.5 ()

55

/MD/CD (/ /)

159 × 216.5 ×
330 mm
140 × 215 ×
260 mm

/MD/CD :
4.9 kg

FM
FM

, FM/AM

87.5 - 108.0 MHz
(50 kHz)
FM
75
10.7 MHz

2.3 kg

(1)

R6 (AA)
(2)

AM (1)

FM (1)

Sony PC
()

AM

531 - 1,602 kHz
(9 kHz)
531 - 1,602 kHz
(9 kHz)
530 - 1,710 kHz
(10 kHz)
AM

450 kHz

Sony 가